

**Agilent E5070A/E5071A ENA Series RF Network Analyzers**

**Manual Supplement for Firmware Version 3.xx**

**Second Edition**



**Agilent Part No. E5070-90017**

**April 2003**

Printed in Japan

---

## Notices

The information contained in this document is subject to change without notice.

This document contains proprietary information that is protected by copyright. All rights are reserved. No part of this document may be photocopied, reproduced, or translated to another language without the prior written consent of Agilent Technologies.

Agilent Technologies Japan, Ltd.

Component Test PGU-Kobe

1-3-2, Murotani, Nishi-ku, Kobe, Hyogo, 651-2241 Japan

MS-DOS, Windows, Windows 98, Windows NT, Visual C++, Visual Basic, VBA and Excel are U.S. registered trademarks of Microsoft Corporation.

Portions ©Copyright 1996, Microsoft Corporation. All rights reserved.

© Copyright Agilent Technologies Japan, Ltd. 2002, 2003

---

## Manual Printing History

The manual's printing date and part number indicate its current edition. The printing date changes when a new edition is printed (minor corrections and updates that are incorporated at reprint do not cause the date to change). The manual part number changes when extensive technical changes are incorporated.

December 2002      First Edition

April 2003          Second Edition

---

## Typeface Conventions

**Sample** key

Indicates a hardkey (key on the front panel or external keyboard) labeled "Sample." "key" may be omitted.

**Sample** menu/button/box

Indicates a menu/button/box on the screen labeled "Sample" which can be selected/executed by clicking. "menu," "button," or "box" may be omitted.

**Sample 1 - Sample 2 - Sample 3**

Indicates a sequential operation of **Sample 1**, **Sample 2**, and **Sample 3** (menu, button, or box). "-" may be omitted.

**1. Using Manuals after Update to Firmware Version 3.0x**

About Manuals with E5070A/E5071A (firmware version 3.0x)	6
Positioning of manuals with E5070B/E5071B	6
Content of this manual	6
Manuals you use with E5070A/E5071A	6
Summary of Differences from E5070B/E5071B	7
Functional differences (functions not available with E5070A/E5071A)	7
Summary of operational differences from E5070B/E5071B	7
How to use this manual	8

**2. Changes to User's Guide**

Summary of Changes	10
Changes Related to Rear Panel	11
Change 1	11
Change 2	12
Changes Related to Setting of Stimulus	13
Change 1	13
Change 2	13
Change 3	14
Change 4	14
Changes Related to Power Calibration	15
Changes Related to GPIB Settings	16
Change 1	16
Change 2	17
Changes Related to Mouse Settings	18
Opening Control Panel window	18
Additional operation after setting	18
Changes Related to Network Connection	19
Change 1	19
Change 2	22
Change 3	25
Changes Related to System Recovery	26
System Recovery	26
Changes Related to Print	29
Change 1	29
Change 2	32

**3. Changes to Programmer's Guide**

Summary of Changes	36
Changes Related to Setting of Sweep Conditions	37
Change 1	37
Change 2	37
Changes Related to SCPI Commands	38
:DISP:TABL:TYPE	38
:SENS{1-16}:SWE:TYPE	38
:SOUR{1-16}:POW:ATT	38
List of Invalid SCPI Commands	39

<b>4. Changes to VBA Programmer's Guide</b>	
Summary of Changes	42
Changes Related to System Configuration	43
Change 1	43
Change 2	44
Changes Related to COM Objects	45
SCPI.DISPlay.TABLe.TYPE	45
SCPI.SENSE(Ch).SWEep.TYPE	45
SCPI.SOURce(Ch).POWer.ATTenuation.DATA	45
List of Invalid COM Objects	46
<b>5. Specifications and Supplemental Information</b>	
Definitions	48
Corrected System Performance	49
Uncorrected System Performance	54
Test Port Output (Source)	55
Test Port Input	57
General Information	61
Measurement Throughput Summary	66
Measurement capabilities	69
Source control	70
Trace functions	70
Data accuracy enhancement	71
Storage	72
System capabilities	72
Automation	73



## About Manuals with E5070A/E5071A (firmware version 3.xx)

### Positioning of manuals with E5070B/E5071B

Although there are some differences in operation between the E5070A/E5071A after update to the firmware version 3.xx (hereafter, simply called E5070A/E5071A) and the E5070B/E5071B (for example, the power sweep function is not provided), you can use most functions almost the same way. Therefore, when you use the E5070A/E5071A, you can use most of the manuals for the E5070B/E5071B by simply replacing the E5070B/E5071B with the E5070A/E5071A. However, because the performance specifications of the instruments differ, use the contents of the E5070A/E5071A user's guide for the "Specifications and Supplemental Information (Chapter 5)."

### Content of this manual

This manual describes the contents<sup>\*1</sup> of the manuals to which you cannot simply apply the contents of the manuals of the E5070B/E5071B for the E5070A/E5071A, in other words, you have to change them.

### Manuals you use with E5070A/E5071A

When using the E5070A/E5071A, use the manuals as follows.

- ❑ User's Guide  
Make the changes described in this manual to the User's Guide of the E5070B/E5071B when using it.
- ❑ Installation/Quick Start Guide  
Use the E5070A/E5071A Installation/Quick Start Guide without any modification.
- ❑ Programmer's Guide  
Make the changes described in this manual to the Programmer's Guide of the E5070B/E5071B when using it.
- ❑ VBA Programmer's Guide  
Make the changes described in this manual to the VBA Programmer's Guide of the E5070B/E5071B when using it.

---

\*1. Most of these changes can be done by replacing them with the E5070A/E5071A manuals.

## Summary of Differences from E5070B/E5071B

### Functional differences (functions not available with E5070A/E5071A)

Among the functions of the E5070B/E5071B, the following functions are not available with the E5070A/E5071A.

- Power sweep
- Power slope
- Power calibration
- Power output exceeding 0 dBm
- Out level setting for each test port
- On/off of the stimulus output

You have to omit the contents relating to the above functions when using the manuals of the E5070B/E5071B for the E5070A/E5071A.

### Summary of operational differences from E5070B/E5071B

Major operational differences between the E5070A/E5071A and the E5070B/E5071B are as follows.

- Differences due to the difference of the Windows operating system (Windows 2000 or Windows 98)
  - Use of networks
  - Use of printers
- Differences due to the conceptual differences of the system controller
  - GPIB setting
  - E5070A/E5071A Control of external devices using VBA
- Others
  - Use of the rear panel
  - Execution of system recovery

You have to make changes to the contents mainly relating to the above differences when using the manuals of the E5070B/E5071B for the E5070A/E5071A.

## **How to use this manual**

This manual describes the contents you need to change or delete when using the manuals of the E5070B/E5071B for the E5070A/E5071A for each manual as follows.

- ❑ Chapter 2, “Changes to User’s Guide,” on page 9
- ❑ Chapter 3, “Changes to Programmer’s Guide,” on page 35
- ❑ Chapter 4, “Changes to VBA Programmer’s Guide,” on page 41

In each chapter, section 1 provides the overview of changes and section 2 and later detail them. Check the contents you need to change in section 1 of each chapter and see the detail of each change as necessary.

Reading section 1 of each chapter before using each manual to find out necessary changes helps you prevent misunderstanding or misoperation due to operational differences between the E5070A/E5071A and the E5070B/E5071B.



---

---

## **2            Changes to User's Guide**

This chapter describes necessary changes when using the E5070B/E5071B User's Guide for the E5070A/E5071A.

## Summary of Changes

You need to make the following changes in the User's Guide in addition to replacing the E5070B/E5071B with the E5070A/E5071A.

Rear panel

Layout of the rear panel differs. Except for the number of the USB ports, the function of each part is the same. For more information on the changes, refer to "Changes Related to Rear Panel" on page 11.

Stimulus settings

Because there are functional restrictions (for example, the power sweep and power slope functions are not provided), you need to delete or change the contents related to them. For more information on the changes, refer to "Changes Related to Setting of Stimulus" on page 13.

Power calibration

The power calibration function is not provided. You need to delete the description related to the power calibration function. For more information, refer to "Changes Related to Power Calibration" on page 15.

GPIB setting

Due to conceptual difference of the system controller, the setting differs. For more information on the changes, refer to "Changes Related to GPIB Settings" on page 16.

Setting mouse

The way the Mouse Properties dialog box opens differs. For more information on the changes, refer to "Changes Related to Mouse Settings" on page 18.

Network

Due to difference of the Windows operating system, procedure of networking differs. For more information on the changes, refer to "Changes Related to Network Connection" on page 19.

System recovery

Operational procedure differs (for example, no floppy disks are necessary for recovery). For more information on the changes, refer to "Changes Related to System Recovery" on page 26.

Print

Due to difference of the Windows operating system, setting of the printer differs. For more information on the changes, refer to "Changes Related to Print" on page 29.

Specifications and reference data

Replace "Specifications and Supplemental Information" in the E5070B/E5071B User's Guide with Chapter 5, "Specifications and Supplemental Information," on page 47.

Restart

For the E5070A/E5071A, there is no concept of restarting the firmware. Replace all the descriptions saying "restarting the firmware" in the E5070B/E5071B User's Guide with "restarting the instrument."

## Changes Related to Rear Panel

### Change 1

Replace Figure 2-8 and Figure 13-1 in the E5070B/E5071B User's Guide with Figure 2-1 and Figure 2-2 respectively.

**Figure 2-1** Rear Panel

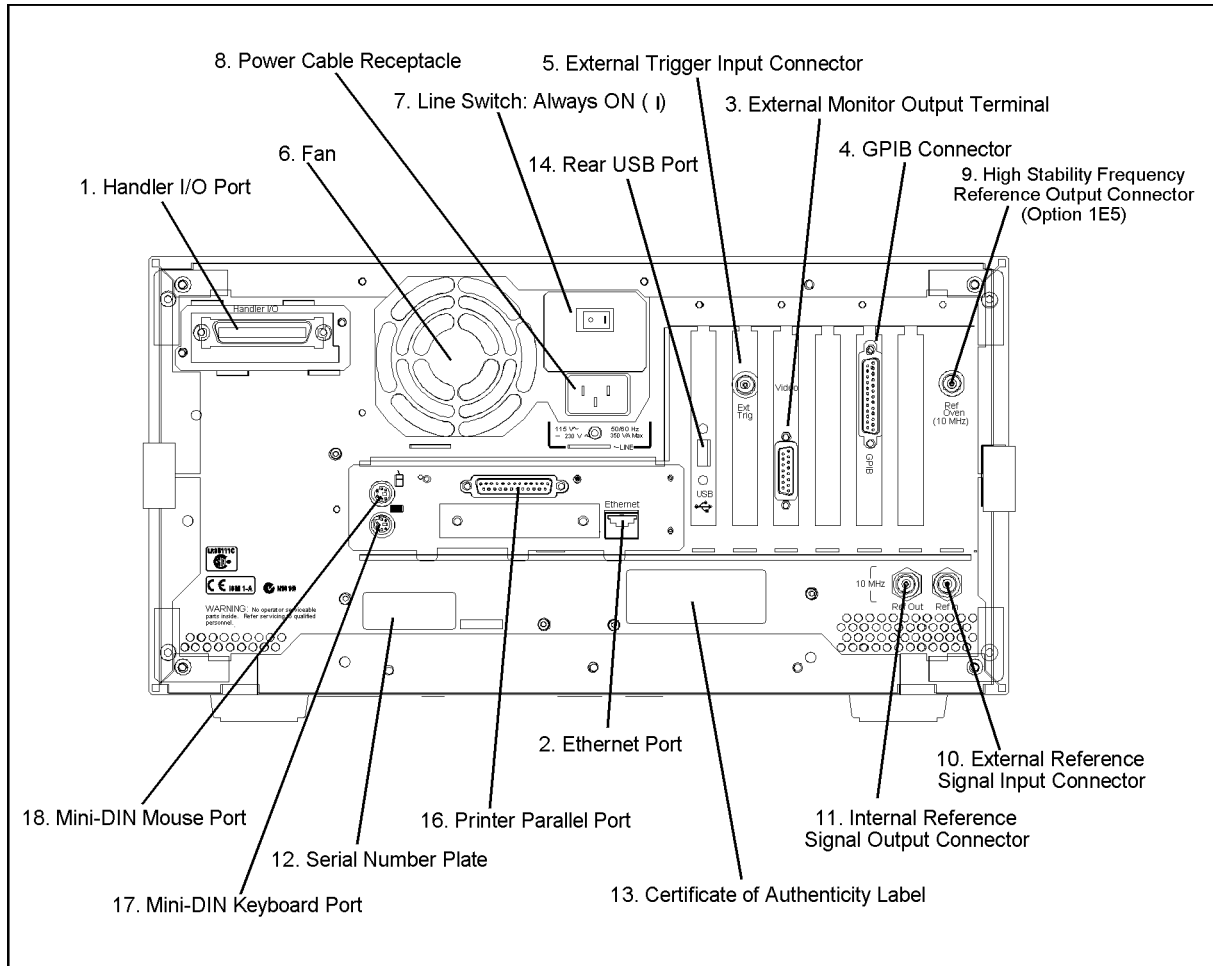

e5070afw3e\_001

Figure 2-2

Connection between the E5070A/E5071A and the E5091A (rear view)

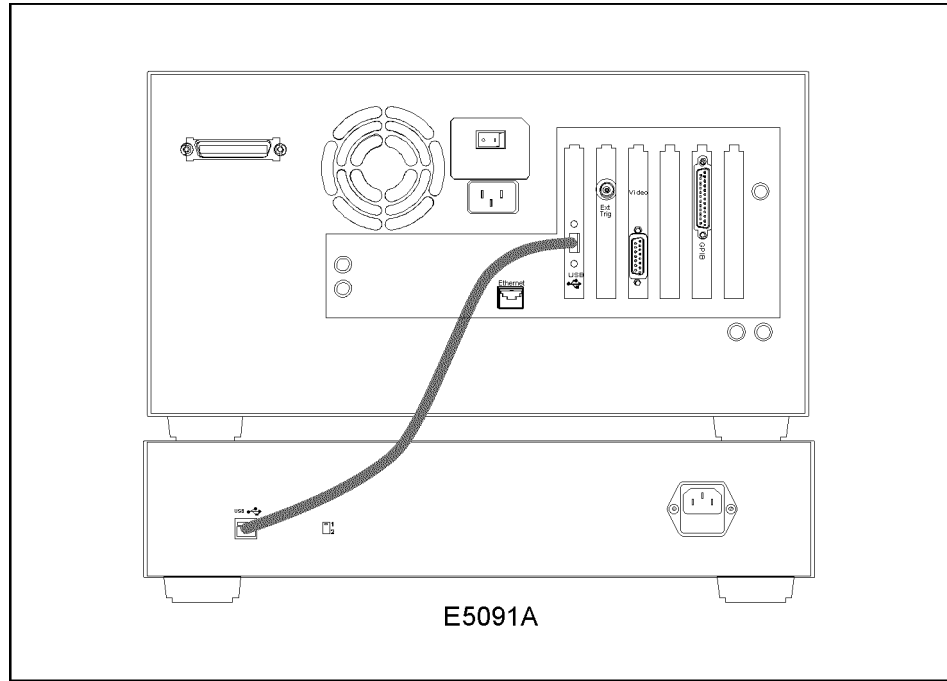

e5070auj190

## Change 2

In Chapter 2 “Overview of functions” in the E5070B/E5071B User’s Guide, replace “14. Rear USB port” of “Rear Panel: Names and Functions of Parts” and “12. Front USB port” of “Front Panel: Names and Functions of Parts” with the following.

### USB Port

A USB (Universal Serial Bus) port (number of parts: 1) specifically for an ECal (Electronic Calibration) module, a multiport test set or a printer. Connecting a designated ECal module to this port enables ECal measurement to be performed. Connecting a designated printer to this port enables screen information on the E5070A/E5071A to be printed to the printer.

---

### NOTE

We do not support connections to the USB port of devices other than designated printers, ECal modules and multiport test sets.

---

---

## Changes Related to Setting of Stimulus

### Change 1

Replace the contents of “Setting sweep type” of “Setting Stimulus Conditions” of Chapter 3 “Setting Measurement Conditions” in the E5070B/E5071B User’s Guide with the following.

#### Setting sweep type

The procedure to select the sweep type is as follows:

- Step 1.** Press **Channel Next** or **Channel Prev** to select the channel for which you want to set the number of points.
- Step 2.** Press **Sweep Setup**.
- Step 3.** Press **Sweep Type**.
- Step 4.** Press the desired softkey to select the sweep type.

Softkey	Function
<b>Lin Freq</b>	Selects the linear sweep.
<b>Log Freq</b>	Selects the logarithmic sweep.
<b>Segment</b>	Selects the linear sweep.

### Change 2

Replace the contents of “Setting power level at frequency sweep” of “Setting Stimulus Conditions” of Chapter 3 “Setting Measurement Conditions” in the E5070B/E5071B User’s Guide with the following.

#### Setting the Power Level

The power level can be set to any value from –15 dBm to 0 dBm (–50 dBm to 0 dBm for models with Option 214, 314, or 414) with a minimum increment of 0.05 dB.

#### Setting the Power Level

- Step 1.** Press **Channel Next** or **Channel Prev** to select the channel for which the power level will be set.
- Step 2.** Press **Sweep Setup**.
- Step 3.** If Option 214, 314, or 414 is installed, follow the procedure below:
  - a.** Press **Power Ranges**.

## Changes to User's Guide

### Changes Related to Setting of Stimulus

b. Press the softkey that corresponds to the desired power range.

Softkey	Function
-15 to 0	Sets the power range to -15 dBm to 0 dBm.
-20 to -5	Sets the power range to -20 dBm to -5 dBm.
-25 to -10	Sets the power range to -25 dBm to -10 dBm.
-30 to -15	Sets the power range to -30 dBm to -15 dBm.
-35 to -20	Sets the power range to -35 dBm to -20 dBm.
-40 to -25	Sets the power range to -40 dBm to -25 dBm.
-45 to -30	Sets the power range to -45 dBm to -30 dBm.
-50 to -35	Sets the power range to -50 dBm to -35 dBm.

**Step 4.** Press **Power**.

**Step 5.** Using the ENTRY block keys on the front panel, input the power level.

### Change 3

Delete “4-3. Rf output OFF indicator” from “Screen Area: Names and Functions of Parts” in Chapter 2 “Overview of Functions” in the E5070B/E5071B User’s Guide. Delete the following sections in “Setting Stimulus Conditions” in Chapter 3 “Setting Measurement Conditions.”

- “On/off of stimulus signal output”
- “Setting fixed frequency at power sweep”

### Change 4

In “Sweep Setup Menu” of Appendix D “Softkey Functions” in the E5070B/E5071B User’s Guide, change the key tree under **Sweep Setup** - **Power** as follows.

Key Operation	Function	SCPI Command
<b>Sweep Setup</b>		
<b>Power</b>	Sets the output power level of the internal signal source of the analyzer.	:SOUR{1-9}:POW
<b>Power Ranges</b>	Displays softkeys for selecting the power range.	
-15 to 0	Sets the power range to -15 dBm to 0 dBm.	:SOUR{1-9}:POW:ATT 0
-20 to -5	Sets the power range to -20 dBm to -5 dBm.	:SOUR{1-9}:POW:ATT 5
-25 to -10	Sets the power range to -25 dBm to -10 dBm.	:SOUR{1-9}:POW:ATT 10
-30 to -15	Sets the power range to -30 dBm to -15 dBm.	:SOUR{1-9}:POW:ATT 15
-35 to -20	Sets the power range to -35 dBm to -20 dBm.	:SOUR{1-9}:POW:ATT 20
-40 to -25	Sets the power range to -40 dBm to -25 dBm.	:SOUR{1-9}:POW:ATT 25
-45 to -30	Sets the power range to -45 dBm to -30 dBm.	:SOUR{1-9}:POW:ATT 30
-50 to -35	Sets the power range to -50 dBm to -35 dBm.	:SOUR{1-9}:POW:ATT 35
<b>Cancel</b>	Returns to the softkey display screen one level higher.	

## Changes Related to Power Calibration

Delete the following from the E5070B/E5071B User's Guide.

- “5-12. Power Calibration Status” of Chapter 2 “Overview of Functions”
- “Power Calibration” of Chapter 4 “Calibration”
- “Executing Power Calibration” of Chapter 14 “Measurement Examples”
- The key tree under  - **Power Calibration** in “Calibration Menu” of Appendix D “Softkey Functions”

## Changes Related to GPIB Settings

### Change 1

Replace the contents of “Setting the GPIB” of Chapter 12 “Setting and Using the Control and Management Functions” in the E5070B/E5071B User’s Guide with the following.

#### Setting the GPIB

This section describes how to set up the interface required to use the GPIB (General Purpose Interface Bus) on the E5070A/E5071A. For more about performing automatic measurements using the GPIB and specific methods of achieving such measurements, see the Programmer’s Guide.

To use the E5070A/E5071A in a GPIB system, you must choose whether to use the E5070A/E5071A as a system controller or in talker/listener mode. One system controller can exist in an automatic measurement system and serves to control the entire system. When the instrument is set in talker/listener mode, however, an address specified for the E5070A/E5071A can be used for control by another device. Therefore, depending on which mode is used, you need to set the address in either system controller mode or talker/listener mode.

#### Setting the GPIB

- Step 1.** Press **System**.
- Step 2.** Press **Misc Setup**.
- Step 3.** Press **GPIB Setup**.
- Step 4.** Press **GPIB Configuration**.
- Step 5.** Press the corresponding softkey to set the control mode.

Softkey	Function
<b>Talker/Listener</b>	Puts the instrument into talker/listener mode.
<b>System Controller</b>	Puts the instrument into system controller mode.

- Step 6.** Press the corresponding softkey to set the address.

Softkey	Function
<b>Talker/Listener Address</b>	Sets the address in talker/listener mode.
<b>System Controller Address</b>	Sets the address in system controller mode.

- Step 7.** Press the standby switch to shut down the E5070A/E5071A.
- Step 8.** Press the standby switch again to turn on the E5070A/E5071A power.

---

**NOTE** The modified control mode and address will not take effect until you shut down the E5070A/E5071A and turn on its power.

---



**Change 2**

In “System Menu” of Appendix D “Softkey Functions” in the E5070B/E5071B User’s Guide, change the key tree under **System** - **Misc Setup** - **GPIB Setup** as follows.

Key Operation	Function	SCPI Command
<b>System</b>		
<b>Misc Setup</b>		
<b>GPIB Setup</b>	Displays softkeys for setting up the GPIB.	
<b>GPIB Configuration</b>	Toggles the GPIB configuration (between talker/listener mode and system controller mode).	None
<b>Talker/Listener Address</b>	Sets the GPIB address for controlling the analyzer from a controller.	None
<b>System Controller Address</b>	Sets an address for using the analyzer as a system controller.	None
<b>Return</b>	Returns to the softkey display screen one level higher.	

---

## Changes Related to Mouse Settings

In Chapter 12 “Setting and Using the Control and Management Functions” in the E5070B/E5071B User’s Guide, change the procedure described in “Setting the Mouse” as follows.

### Opening Control Panel window

Change the procedure until you open the Control Panel window as follows.

- Step 1.** Press **[System]**.
- Step 2.** Press **Misc Setup**.
- Step 3.** Click **Service Menu - Restart Menu** on the menu bar, and the Password dialog box will open.
- Step 4.** Enter the password, **e507xa**, into the **Password** box.
- Step 5.** Click **Restart as Service** on the menu bar, and the instrument will be restarted.
- Step 6.** Move the mouse pointer to the lower-left corner of the E5070A/E5071A screen and click **Start - Settings - Control Panel** to open the Control Panel window.

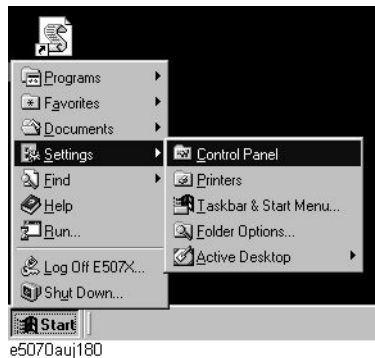

### Additional operation after setting

Do the following after setting the mouse.

Double-click the **Restart as Inst** icon (Figure 2-3) on the screen. A confirmation message appears. Click **OK** to respond. The E5070A/E5071A restarts and runs as the instrument.

Figure 2-3

#### Restart as Inst icon



## Changes Related to Network Connection

### Change 1

Replace the contents of “Configuring the Network” of Chapter 12 “Setting and Using the Control and Management Functions” in the E5070B/E5071B User’s Guide with the following.

#### Enable/Disable the Network Connection Function.

You can enable or disable the network connection function of the E5070A/E5071A.

#### Operating Step

- Step 1.** Press **System**.
- Step 2.** Press **Misc Setup**.
- Step 3.** Press **Network Setup**.
- Step 4.** Press **Network Device** to **ENABLE** or **DISABLE** the network connection function.
- Step 5.** A dialog box will appear that confirms to reboot the instrument or not, press **OK** to reboot.

#### Configuring the Network

This section describes how to make the settings required to connect the E5070A/E5071A to a LAN (local area network). For details of how to use a LAN, see the Programmer’s Guide.

---

**NOTE**

When connecting the E5070A/E5071A to a LAN, consult the network administrator about the proper LAN settings.

#### Configuring the Network

- Step 1.** Use the LAN cable to connect the E5070A/E5071A to the LAN.
- Step 2.** Press **System**.
- Step 3.** Press **Misc Setup**.
- Step 4.** Press **Network Setup**.
- Step 5.** Press **Network Configuration**.
- Step 6.** The Network dialog box (Figure 2-4) will appear. In the **Configuration** tab, select **TCP/IP** (display it in reverse video) and press the **Properties** button.

Figure 2-4 Network Dialog Box ("Configuration" Tab)

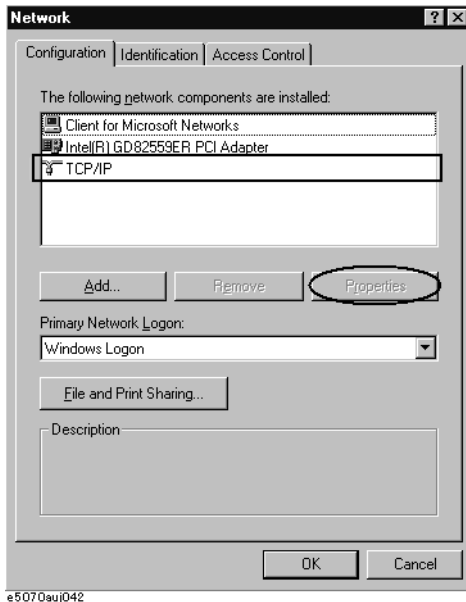

Step 7. The dialog box in Figure 2-5 appears.

To assign a specific IP address and subnet mask, select the **Specify an IP address** option button within the **IP Address** tab and enter an IP address into the **IP Address** box and a subnet mask into the **Subnet Mask** box (write them over the initial values).

If an IP address can be obtained automatically (i.e., you can use the DHCP server), click and select **Obtain an IP address automatically**. In this case, it is not necessary to set a gateway address in Step 8.

Figure 2-5 TCP/IP Properties Dialog Box ("IP Address" Tab)

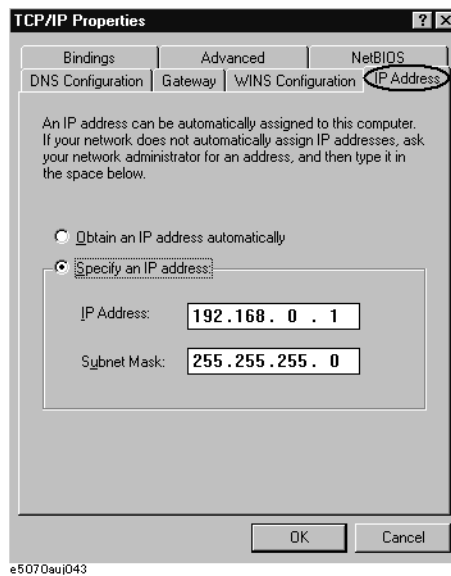

- Step 8.** Select the **Gateway** tab. The dialog box in Figure 2-6 appears, enter a correct gateway address in the **New gateway** box and press the **Add** button.

Figure 2-6

TCP/IP Properties Dialog Box (“Gateway” Tab)

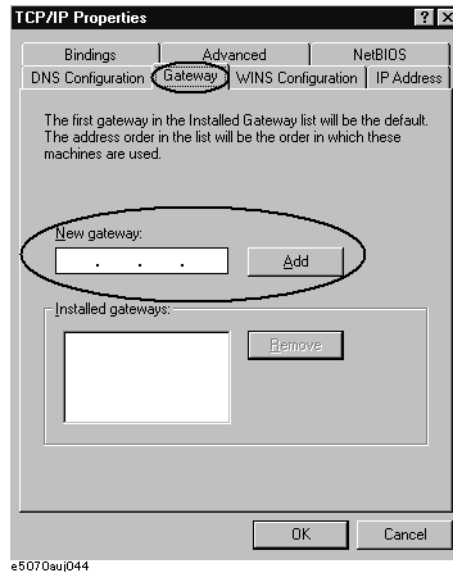

- Step 9.** In the Network dialog box, select **Identification** tab. The dialog box in Figure 2-7 appears. If another computer name is required other than **E507X**, set in the **Computer Name** box.

Figure 2-7

Network Dialog Box (“Identification” Tab)

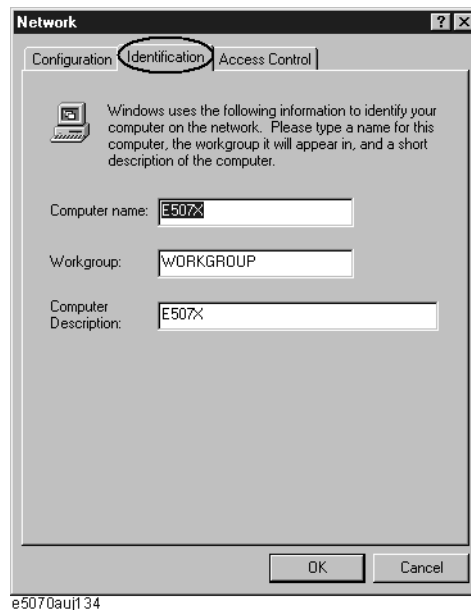

- Step 10.** If another network configuration is required, follow the same procedure to configure a network on a Windows 98<sup>®</sup> PC.
- Step 11.** Press the **OK** button to close the TCP/IP Properties dialog box.

**Step 12.** Press the **OK** button to close the Network dialog box.

**Step 13.** The System Settings Change dialog box (Figure 2-8) now appears, press the **Yes** button to shut down the E5070A/E5071A.

**Figure 2-8** System Settings Change Dialog Box

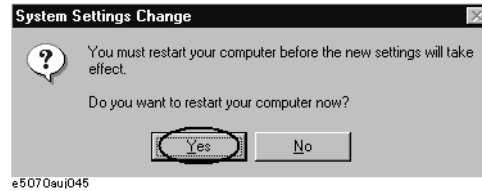

---

**NOTE** The modified network configuration will not take effect until you shut down and restart the E5070A/E5071A.

---

## Change 2

Replace the contents of “Accessing Hard Disk of E5070B/E5071B from External PC” of Chapter 12 “Setting and Using the Control and Management Functions” in the E5070B/E5071B User’s Guide with the following.

### Accessing to hard disk of the E5070A/E5071A from an external PC via LAN

If you connect the E5070A/E5071A to LAN, you can access the hard disk (D drive) in the E5070A/E5071A as a network drive from an external PC connected to the same LAN.

---

**NOTE** Accessing the hard disk of the external PC connected to the same LAN from the E5070A/E5071A is not supported.

---

**Figure 2-9** Accessing to drive D of E5070A/E5071A from external PC

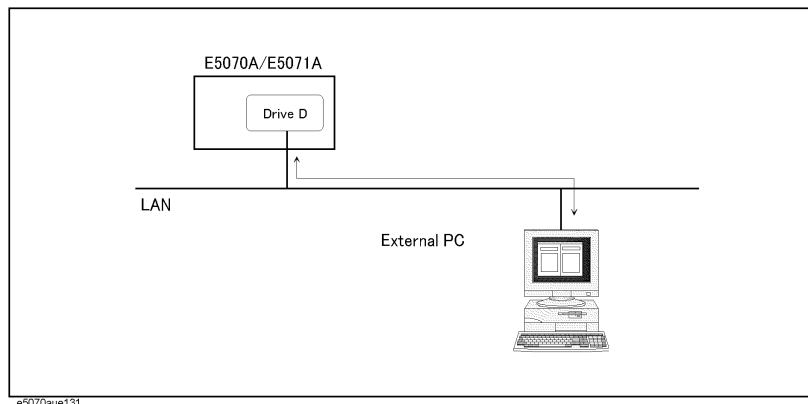

### Enabling access from external PC

---

**NOTE** You need to make the setting to enable the connection to LAN in advance. For more information, refer to “Configuring the Network” on page 19.

---

- Step 1. Press **System**.
- Step 2. Press **Network Configuration**.
- Step 3. The Network dialog box as shown in Figure 2-10 appears. Click the **File and Print Sharing...** button.

Figure 2-10

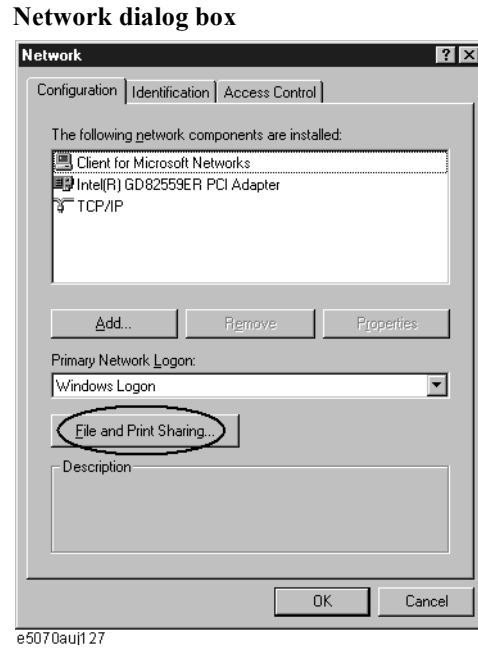

- Step 4. The File and Print Sharing dialog box as shown in Figure 2-11 appears. Check **I want to be able to give others access to my files** and click the **OK** button.

Figure 2-11

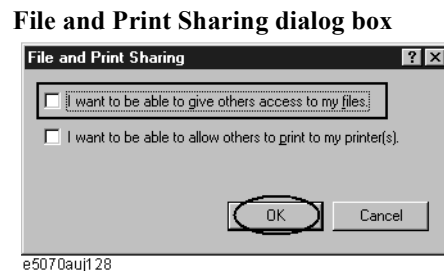

- Step 5. Click the **OK** button in the Network dialog box (see Figure 2-10).
- Step 6. The System Setting Change dialog box as shown in Figure 2-12 appears. Click the **Yes** button to restart.

Figure 2-12

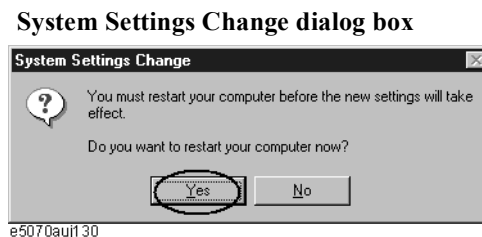

## Changes to User's Guide

### Changes Related to Network Connection

#### Accessing to hard disk of E5070A/E5071A from external PC

This section describes the procedure to connect to the hard disk (drive D) in the E5070A/E5071A from the external PC, taking Windows 98 ® as an example. For information on connection, see your PC's operation manual.

- Step 1.** From the Start menu, click Programs - Windows Explorer to start the Explorer.
- Step 2.** From the Explorer's menu, click **Tools - Map Network Drive...**
- Step 3.** The Map Network Drive dialog box appears. Select an appropriate drive (1 in Figure 2-13), enter **\\e507x\user\$** as the network path (2 in Figure 2-13), and then click the **OK** button.

**Figure 2-13** Map Network Drive dialog box

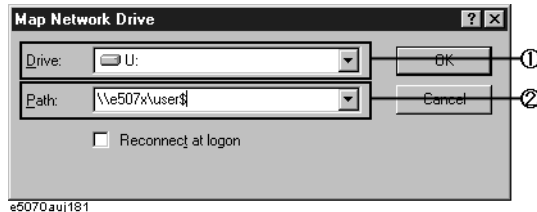

---

**NOTE** **e507x** in the network path is the computer name of the E5070A/E5071A. If you changed the computer name when setting the network, use the computer name you changed instead of **e507x**.

---

---

**NOTE** If you use another OS such as Windows NT®, you may be prompted to enter the user name but you can leave it blank.

---

- Step 4.** The Enter Network Password dialog box appears. Enter the password, **e507xa**, and then click the **OK** button. The D drive of the E5070A/E5071A is connected to the PC.

**Figure 2-14** Enter Network Password dialog box

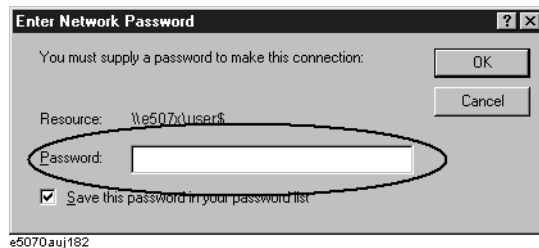



### Change 3

In “System Menu” of Appendix D “Softkey Functions” in the E5070B/E5071B User’s Guide, change the key tree under **System** - **Misc Setup** - **Network Setup** as follows.

Key Operation	Function	SCPI Command
<b>System</b>		
<b>Misc Setup</b>		
<b>Network Setup</b>	Displays softkeys for configuring network settings.	
<b>Telnet Server</b>	Enables or disables the telnet server function.	None
<b>Network Configuration</b>	Opens a dialog box for configuring network settings.	None
<b>Network Device</b>	Enables or disables the network device function.	None
<b>Return</b>	Returns to the softkey display screen one level higher.	

---

## Changes Related to System Recovery

Replace the contents of “System Recovery” of Chapter 12 “Setting and Using the Control and Management Functions” in the E5070B/E5071B User’s Guide with the following.

### System Recovery

By executing system recovery, you can return the Windows operating system and the firmware of the E5070A/E5071A to the state when you purchased it \*1.

#### Notes on executing system recovery

Executing system recovery causes the following:

- The following settings of the E5070A/E5071A are initialized.
  - Network setting
  - GPIB setting
  - Printer setting
- If the firmware has been updated after purchasing the E5070A/E5071A, the firmware when you purchased the product \*1 is recovered.
- The driver for the supported printer you installed is deleted.

Files you created using the save function (files in the D drive) are not affected, but we recommend backing them up before executing system recovery for precautionary purposes.

#### Procedure to execute system recovery

---

#### NOTE

You need the keyboard and the mouse for this operation.

- Step 1.** Shut down the E5070A/E5071A.
- Step 2.** Connect the keyboard and the mouse to the E5070A/E5071A.
- Step 3.** Press the standby switch of the E5070A/E5071A to turn it on.
- Step 4.** When the message in the figure below appears on the screen following the Agilent's logo screen (white screen), immediately press **[R]** on the keyboard.

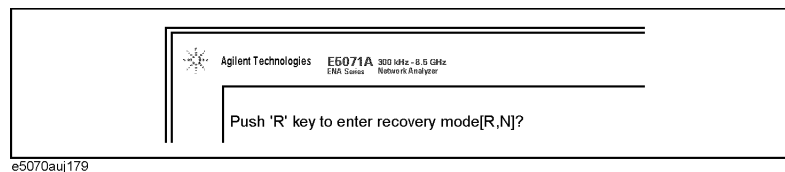

---

#### NOTE

After several seconds, the next screen appears automatically even if you do not press any key, so do not miss it.

---

\*1. If the hard disk failed and has been replaced after purchase, the state when the replacement was performed is recovered.

If the above message does not appear, the instrument is at fault; contact your local Agilent customer center listed at the end of this manual or distributor.

**Step 5.** When "Recover Hard disk (C drive) [Y, N]?" is displayed, press  on the keyboard. If you want to quit the system recovery, press  to start up the E5070A/E5071A as usual.

**Step 6.** The following message appears. This is the final confirmation message asking whether you want to start the system recover. Press  on the keyboard to start the system recovery. If you want to quit the system recovery, press  to start up the E5070A/E5071A as usual.

```
=====
SYSTEM RECOVERY
=====
```

```
This process will recover the system drive (C:) of this
instrument to the factory-shipment state. It takes about 30 minutes.
Please refer to the Operation Manual for more information.
```

```
This is the last chance to quit the recovery process
```

```
Continue [Y,N]?
```

**Step 7.** The system recovery will be complete in about 15 minutes. The following message is displayed during the system recovery.

```
=====
SYSTEM RECOVERY IN PROGRESS....
=====
```

```
System recovery in progress. It takes about 30 minutes.
Please DO NOT TURN THE POWER OFF DURING THIS TIME.
```

---

**CAUTION**

**Never turn off the power during the system recovery because doing so may cause serious damage to the E5070A/E5071A.**

**Step 8.** After the completion of the system recovery, the System Setting Change dialog box as shown in Figure 2-12 appears. Click the **Yes** button to restart.

**Figure 2-15**

**System Setting Change dialog box**



- Step 9.** After restart, the Enter Network Password dialog box as shown in Figure 2-16 appears. **Enter nothing** and click the **OK** button.

**Figure 2-16** Enter Network Password dialog box

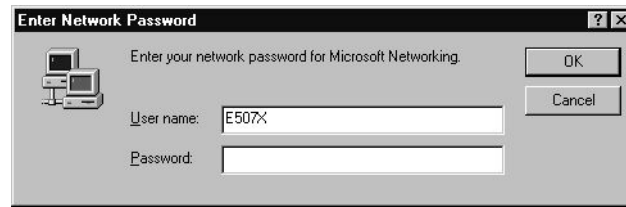

---

**NOTE**

If you enter the password here, each time you start the instrument, the Enter Network Password dialog box appears and asks you to enter the password. If you click the **Cancel** button, the Enter Network Password dialog box will appear again at the next startup.

---

- Step 10.** The System Setup Complete dialog box appears. Click the **OK** button to restart.

Note that, if the system calibration data file has a problem, the Recovery Failed dialog box as shown in Figure 2-17 appears instead of the System Setup Complete dialog box, and then the System Setup **Incomplete** dialog box appears.

**Figure 2-17** Recovery Failed dialog box

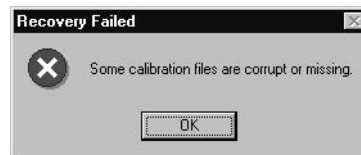

---

**NOTE**

If the Recovery Failed dialog box and the System Setup Incomplete dialog box appear or if the problem persists even if you executing the system recovery, the instrument is at fault. Contact your local Agilent Technologies customer center listed at the end of this manual or distributor.

---

- Step 11.** For the E5070A/E5071A equipped with the Option 016 touch screen, execute the calibration of the touch screen.

Now the system recovery of the E5070A/E5071A is complete.

---

## Changes Related to Print

### Change 1

Replace the contents of “Print procedure” of “Printing Displayed Screen” of Chapter 9 “Data Output” in the E5070B/E5071B User’s Guide with the following.

#### Printing the screen image

Follow the procedure below to print the screen image.

- Step 1.** Connect a printer to the parallel port of E5070A/E5071A or USB port while the E5070A/E5071A is on. Turn on the printer.

---

**NOTE**

Do not connect printers other than those supported by the E5070A/E5071A. An incorrect connection may cause the Add New Hardware wizard to be displayed on the screen. If this happens, terminate the Add New Hardware wizard by clicking the **Cancel** button.

---

**NOTE**

For the E5070A/E5071A, when you want to use the printer by connecting it to the USB port, you need to register the printer first. For more information, refer to “Registering the printer” on page 32

- Step 2.** Display the window to be printed.

- Step 3.** Press **[System]** to open the System menu. Use the softkeys displayed to complete the printing.

Softkey	Function
<b>Print</b>	Starts printing.
<b>Abort Printing</b>	Aborts printing.
<b>Printer Setup</b>	Allows the user to select and set up a printer.
<b>Invert Image</b>	Allows the user to print either with colors closest to the screen display [OFF] or with inverted colors [ON].

**Step 4.** Press **Printer Setup** to open the Print dialog box as shown in Figure 2-18. When the dialog box appears, use the external keyboard and mouse to complete the printing.

Figure 2-18

Print Setup Dialog Box

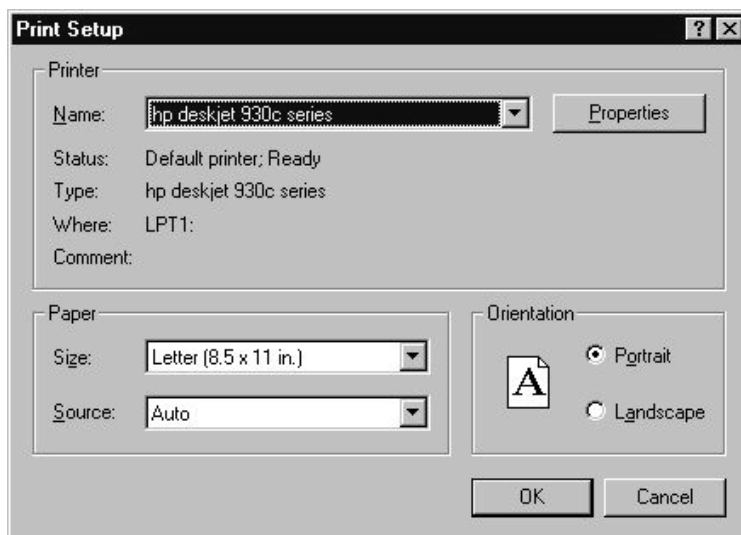

**Step 5.** Select the destination printer in the **Name** box in the **Printer** area.

**NOTE**

The user may select the pre-installed printer or another printer that corresponds to a new printer driver installed according to “Registering the printer” on page 32.

**Step 6.** Follow the instructions below to set up the printer.

Table 2-1

Using the Print Setup Dialog Box

Setup Item	Operation
Paper setup	Select the paper size in the <b>Paper Settings</b> area. Also select the orientation of the paper in the <b>Orientation</b> area.
Printer properties setup	For setting printer properties other than the paper setup, click <b>Properties</b> in the <b>Printer</b> area to open a dialog box. Make the necessary changes in the dialog box (Figure 2-19 shows the dialog box for the HP DeskJet 930C printer driver).

Figure 2-19

HP DeskJet 930C Series Dialog Box

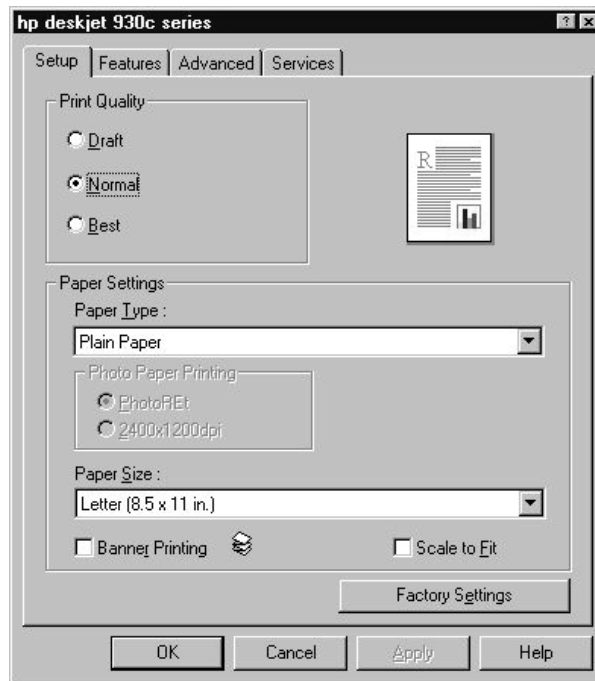

**Step 7.** Press **Invert Image** to print either in colors closest to the screen display [OFF] or in inverted colors [ON], as necessary.

**Step 8.** Press **Print** to start printing. To cancel the printing in progress, press **Abort Printing**.

---

**NOTE**

Issuing the Print instruction when the printer is not ready (e.g., the power is not on) may result in displaying the Printers Folder dialog box shown in Figure 2-20. If this happens, first close the Printers Folder dialog box by clicking **Cancel**, ready the printer, and then restart the printing.

---

Figure 2-20

Printers Folder Dialog Box



## Change 2

Add the following section to “Printing Displayed Screen” of Chapter 9 “Data Output” in the E5070B/E5071B User's Guide.

### Registering the printer

From the Print dialog box (refer to Figure 2-23 on page 34), you can select from the registered printers only. Therefore, when you use the printer for the first time, you need to register the printer first. When you use a printer supported at the time of shipment with the parallel port, it is already registered at the factory and therefore you need not to register it yourself.

---

**NOTE** In the case of the USB port, the ID of the printer is also registered. Therefore, when you use a printer different from one used for the registration, even if it is of the same model, you need to register the printer again. When using the parallel port, you need not to register the printer again as long as you use a printer of the same model.

---

The registration procedure is as follows:

---

**NOTE** You need the mouse and the keyboard for this operation.

---

#### Step 1. Restart the E5070A/E5071A in the service mode

- i. Press **System**.
- ii. Press **Service Menu - Restart Menu**. The Password dialog box opens.
- iii. Enter the password **e507xa** in the **Password** box and click the **OK** button.
- iv. Press **Restart as Service**. The instrument is restarted and the Windows screen appears.

#### Step 2. Connect the printer

Turn on the printer and connect it to the E5070A/E5071A.

**Step 3.** Move the mouse pointer to the lower left part of the screen of the E5070A/E5071A and click **Start - Settings - Printers** (see the below figure) to open the Printers window.

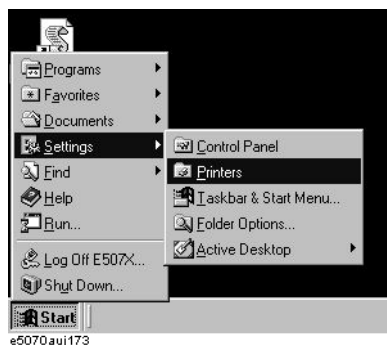

**Step 4.** Double-click the Add Printer icon in the Printers window to start Add Printer Wizard.

**Step 5.** On the first screen of Add Printer Wizard, click **Next**. When the screen shown in the below



figure, check that “Local printer” is selected and click **Next**.

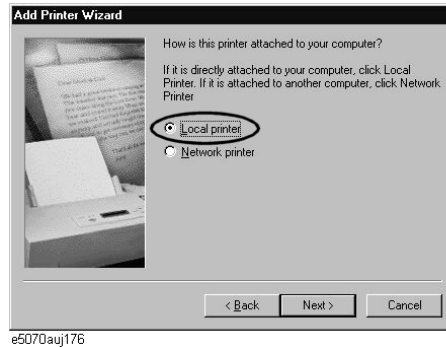

**Step 6.** The screen to select the manufacturer and model name of the printer appears. Select the manufacturer (1 in Figure 2-21) and the model name (2 in Figure 2-21) and then click **Next**.

**CAUTION**

Do not select other than supported printers because doing so may give serious damage to the E5070A/E5071A.

**Figure 2-21** Selecting manufacturer and model name (example for Hewlett Packard Deskjet 930C)

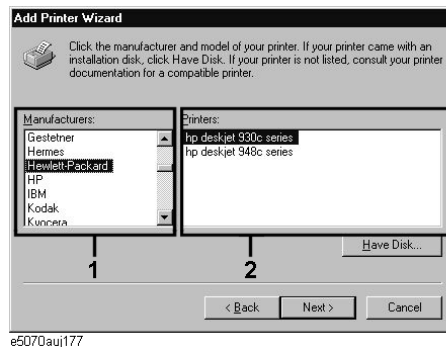

**Step 7.** If the screen that asks you whether you want to keep the existing printer driver, select “Keep existing driver[recommended]” as shown below and click **Next**.

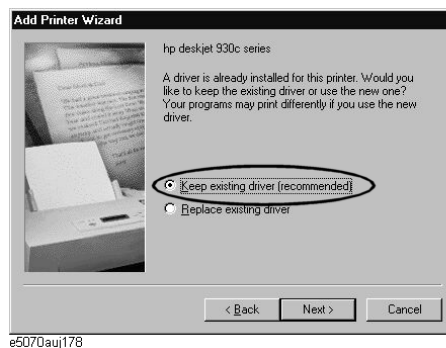

## Changes to User's Guide Changes Related to Print

**Step 8.** The screen to select the connection port appears. Select the port to which you connect the printer (LPT1 or USB...) and click **Next**.

Figure 2-22

### Selecting connection port (when selecting the USB port)

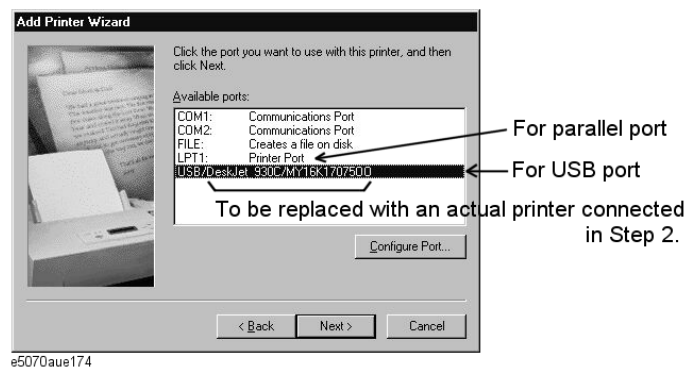

**Step 9.** The screen to enter the printer name appears. Enter the printer name (1 in Figure 2-23), select whether to set it to the default printer (2 in Figure 2-23), and click **Finish**. Use the printer name you have specified here when selecting the printer in the Print dialog box (see Figure 2-23 on page 34).

Figure 2-23

### Entering printer name

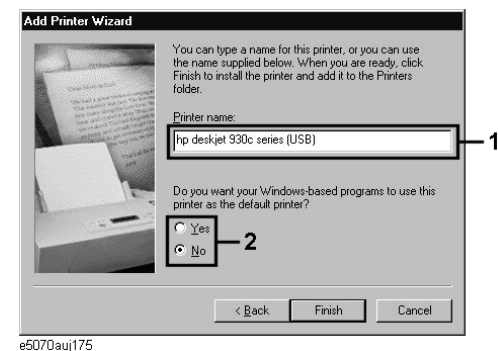

**Step 10. Restart the E5070A/E5071A in the instrument mode**

Double-click the Restart as Inst icon on the desktop (see Figure 2-24). The confirmation message appears. Click **OK**. The E5070A/E5071A is restarted and starts up as the instrument.

Figure 2-24

### Restart as Inst icon



---

---

# 3

## Changes to Programmer's Guide

This chapter describes necessary changes when using the E5070B/E5071B Programmer's Guide for the E5070A/E5071A.

## Summary of Changes

You need to make the following changes in the Programmer's Guide in addition to replacing the E5070B/E5071B with the E5070A/E5071A.

Setting sweep conditions

Because there are functional restrictions (for example, the power sweep and power slope functions are not provided), you need to delete or change the contents related to them. For more information, refer to "Changes Related to Setting of Sweep Conditions" on page 37.

Power calibration

The power calibration function is not provided. Delete "Power calibration" of "Sample programs" in Chapter 4 "Calibration" in the E5070B/E5071B Programmer's Guide.

SCPI commands

Due to functional differences, some commands have different specifications. For more information, refer to "Changes Related to SCPI Commands" on page 38.

None of the commands are available for the functions that the E5070A/E5071A does not provide. For more information, refer to "List of Invalid SCPI Commands" on page 39.

## Changes Related to Setting of Sweep Conditions

### Change 1

Replace the contents of “Setting Power Level” of “Configuring Measurement Conditions” in Chapter 3 “Setting Up the Analyzer” in the E5070B/E5071B Programmer’s Guide with the following.

#### Setting Power Level

To set the power, use the following command:

- **:SOUR{1-16}:POW**

When the instrument is equipped with the power range extension option, you can also set the power range using the following command:

- **:SOUR{1-16}:POW:ATT**

### Change 2

Delete the following sections in “Configuring Measurement Conditions” in Chapter 3 “Setting Up the Analyzer” in the E5070B/E5071B Programmer’s Guide.

- “Turning On/Off of Stimulus Signal Output”
- “Configuring Power Sweep Settings”

## Changes Related to SCPI Commands

### **:DISP:TABL:TYPE**

Delete the following parameters because they are not available.

- PLOSs
- SCFactor

### **:SENS{1-16}:SWE:TYPE**

Delete the following parameters because they are not available.

- POWER

### **:SOUR{1-16}:POW:ATT**

Replace the table of the relationship between the attenuator value and the power range with the following table.

<b>Attenuator</b>	<b>Power range</b>	<b>Attenuator</b>	<b>Power range</b>
0 dB	-15 to 0 dBm	5 dB	-20 to -5 dBm
10 dB	-25 to -10 dBm	15 dB	-30 to -15 dBm
20 dB	-35 to -20 dBm	25 dB	-40 to -25 dBm
30 dB	-45 to -30 dBm	35 dB	-50 to -35 dBm

## List of Invalid SCPI Commands

The following commands are not available. Delete them from the manual.

**:OUTP**  
**:SENS{1-16}:FREQ**  
**:SOUR:POW:PORT:CORR:COLL:ASEN:RCF**  
**:SOUR:POW:PORT:CORR:COLL:BSEN:RCF**  
**:SOUR:POW:PORT:CORR:COLL:TABL:ASEN:DATA**  
**:SOUR:POW:PORT:CORR:COLL:TABL:BSEN:DATA**  
**:SOUR{1-16}:POW:CENT**  
**:SOUR{1-16}:POW:PORT:COUP**  
**:SOUR{1-16}:POW:PORT{1-4}**  
**:SOUR{1-16}:POW:PORT{1-4}:CORR**  
**:SOUR{1-16}:POW:PORT{1-4}:CORR:COLL**  
**:SOUR{1-16}:POW:PORT{1-4}:CORR:COLL:AVER**  
**:SOUR{1-16}:POW:PORT{1-4}:CORR:DATA**  
**:SOUR{1-16}:POW:PORT{1-4}:CORR:COLL:TABL:LOSS**  
**:SOUR{1-16}:POW:PORT{1-4}:CORR:COLL:TABL:LOSS:DATA**  
**:SOUR{1-16}:POW:SLOP**  
**:SOUR{1-16}:POW:SLOP:STAT**  
**:SOUR{1-16}:POW:SPAN**  
**:SOUR{1-16}:POW:STAR**  
**:SOUR{1-16}:POW:STOP**  
**:SYST:COMM:GPIB:PMET:ADDR**

Changes to Programmer's Guide  
**List of Invalid SCPI Commands**





## Summary of Changes

You need to make the following changes in the VBA Programmer's Guide in addition to replacing the E5070B/E5071B with the E5070A/E5071A.

System configuration

Due to the conceptual difference of the system controller, the system configuration to control peripherals with VBA differs. For more information on the changes, refer to "Changes Related to System Configuration" on page 43.

Power calibration

The power calibration function is not provided. Delete "Power calibration" of "Sample programs" in Chapter 4 "Calibration" in the E5070B/E5071B Programmer's Guide.

COM objects

Due to functional differences, some objects have different specifications. For more information, refer to "Changes Related to COM Objects" on page 45.

None of the objects are available for the functions that the E5070A/E5071A does not provide. For more information, refer to "List of Invalid COM Objects" on page 46.

## Changes Related to System Configuration

### Change 1

Replace the contents of “Implementing a Control System” in Chapter 2 “Introduction to VBA Programming” in the E5070B/E5071B VBA Programmer’s Guide with the following.

#### Implementing a Control System

Macro-based control systems are classified into two types: As shown in Figure 4-1, a VBA control system controls the E5070A/E5071A itself while a VBA remote control system controls peripherals. When you use the macro function to control peripherals, you must connect the E5070A/E5071A with the peripherals through GPIB cables, and configure them to communicate over VISA.

Figure 4-1

Example of configuring a control system using the macro function

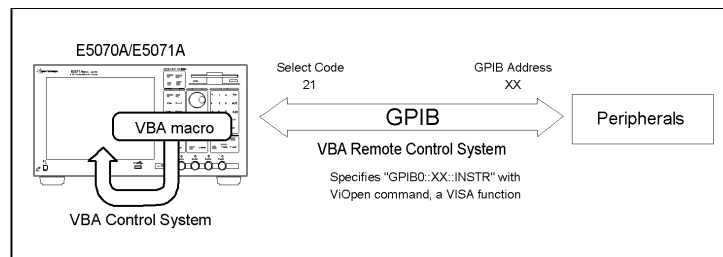

e5070ave013

#### Required Equipment

1. E5070A/E5071A
2. Peripherals and/or other instruments that serve your purpose
3. GPIB cables for connecting the E5070A/E5071A with the peripherals

#### Required Configuration Tasks

When you use the macro function to control the E5070A/E5071A itself, you do not need to be aware of the active control settings for the GPIB system. This means that you do not need to be aware of the settings of Talker/Listener mode (where the E5070A/E5071A is controlled from an external controller) and System Controller mode (where the E5070A/E5071A acts as a controller to peripherals).

However, when you use the macro function to control peripherals, they will be actually controlled through the E5070A/E5071A's built-in GPIB, and therefore you must configure the E5070A/E5071A to work in System Controller mode.

- Step 1.** Configure the E5070A/E5071A to work in System Controller mode.
  - **[System] - GPIB Setup - GPIB Configuration (System Controller)**
- Step 2.** Configure the system controller's GPIB address. "XX" represents an address number.
  - **[System] - GPIB Setup - System Controller Address (XX)**
- Step 3.** Turn off the E5070A/E5071A and turn it on.

## Change 2

Replace the contents of "Overview" in Chapter 5 "Controlling Peripherals" in the E5070B/E5071B VBA Programmer's Guide with the following.

### Overview

The E5070A/E5071A macro function (E5070A/E5071A VBA) can be used not only to automate measurements but also to control external measurement instruments connected via GPIB cables by acting as a self-contained system controller (see "An Overview of a Control System Based on the Macro Function" on page 21).

The E5070A/E5071A macro function (E5070A/E5071A VBA) performs communications via the COM interface when controlling the E5070A/E5071A itself, but it communicates via VISA (Virtual Instrument Software Architecture) when controlling external measurement instruments.

To control peripherals connected to the E5070A/E5071A via GPIB, the following two preparations are required.

### Preparations

#### 1. Placing E5070A/E5071A in System Control Mode

When the E5070A/E5071A and its peripherals are controlled with the E5070A/E5071A macro function, this is done via the GPIB bus inside the E5070A/E5071A. Therefore, you need to set the GPIB system's control mode to the system controller mode. Then you need to set the GPIB address as the system controller.

#### 2. Importing Definition Files

To use the VISA library in the E5070A/E5071A macro (E5070A/E5071A VBA), you need to import two definition files into your project with the Visual Basic editor to define the VISA functions and perform other tasks. The definition files are stored on the sample programs disk under the following filenames.

- visa32.bas
- vpptype.bas

## Changes Related to COM Objects

### SCPI.DISPlay.TABLe.TYPE

Delete the following parameters because they are not available.

- PLOSs
- SCFactor

### SCPI.SENSE(*Ch*).SWEep.TYPE

Delete the following parameters because they are not available.

- POWER

### SCPI.SOURce(*Ch*).POWER.ATTenuation.DATA

Replace the table of the relationship between the attenuator value and the power range with the following table.

Description	Power ranges	Setting
	-15 to 0[dB]	0
	-20 to -5[dB]	5
	-25 to -10[dB]	10
	-30 to -15[dB]	15
	-35 to -20[dB]	20
	-40 to -25[dB]	25
	-45 to -30[dB]	30
	-50 to -35[dB]	35

## List of Invalid COM Objects

The following objects are not available. Delete them from the manual.

**SCPI.OUTPUT.STATE**  
**SCPI.SENSE(Ch).FREQUENCY.CW**  
**SCPI.SENSE(Ch).FREQUENCY.FIXED**  
**SCPI.SOURCE(Ch).POWER.CENTER**  
**SCPI.SOURCE(Ch).POWER.LEVEL.SLOPE.STATE**  
**SCPI.SOURCE(Ch).POWER.LEVEL.SLOPE.DATA**  
**SCPI.SOURCE(Ch).POWER.PORT(Pt).LEVEL.IMMEDIATE.AMPLITUDE**  
**SCPI.SOURCE(Ch).POWER.PORT.COUPLE**  
**SCPI.SOURCE(Ch).POWER.PORT(Pt).CORRECTION.STATE**  
**SCPI.SOURCE(Ch).POWER.PORT(Pt).CORRECTION.COLLECT.ACQUIRE**  
**SCPI.SOURCE.POWER.PORT.CORRECTION.COLLECT.ASENSOR.RCFactor**  
**SCPI.SOURCE(Ch).POWER.PORT(Pt).CORRECTION.COLLECT.AVERAGE.COUNT**  
**SCPI.SOURCE.POWER.PORT.CORRECTION.COLLECT.BSENSOR.RCFactor**  
**SCPI.SOURCE.POWER.PORT.CORRECTION.COLLECT.TABLE.ASENSOR.DATA**  
**SCPI.SOURCE.POWER.PORT.CORRECTION.COLLECT.TABLE.BSENSOR.DATA**  
**SCPI.SOURCE(Ch).POWER.PORT(Pt).CORRECTION.COLLECT.TABLE.LOSS.STATE**  
**SCPI.SOURCE(Ch).POWER.PORT(Pt).CORRECTION.COLLECT.TABLE.LOSS.DATA**  
**SCPI.SOURCE(Ch).POWER.PORT(Pt).CORRECTION.DATA**  
**SCPI.SOURCE(Ch).POWER.SPAN**  
**SCPI.SOURCE(Ch).POWER.START**  
**SCPI.SOURCE(Ch).POWER.STOP**  
**SCPI.SYSTEM.COMMUNICATE.GPIB.PMETER.ADDRESS**



## Definitions

All specifications apply over a 5°C to 40°C range (unless otherwise stated) and 90 minutes after the instrument has been turned on.

**Specification (spec.):** Warranted performance. Specifications include guardbands to account for the expected statistical performance distribution, measurement uncertainties, and changes in performance due to environmental conditions.

Supplemental information is intended to provide information that is helpful for using the instrument but that is not guaranteed by the product warranty. This information is denoted as either typical or nominal.

**Typical (typ.):** Expected performance of an average unit that does not include guardbands. It is not guaranteed by the product warranty.

**Nominal (nom.):** A general, descriptive term that does not imply a level of performance. It is not guaranteed by the product warranty.



## Corrected System Performance

The specifications in this section apply for measurements made with the Agilent E5070A/E5071A Network Analyzer under the following conditions:

- No averaging applied to data
- Environmental temperature of 23°C ±5°C, with less than 1°C deviation from the calibration temperature
- Response and isolation calibration not omitted

**Table 5-1 System Dynamic Range**

Description		Specification	Supplemental Information
<b>System Dynamic Range <sup>*1*2</sup></b>			
300 kHz to 3 MHz	IF bandwidth = 3 kHz		85 dB
3 MHz to 1.5 GHz		95 dB	98 dB
1.5 GHz to 4 GHz		97 dB	100 dB
4 GHz to 6 GHz		95 dB	97 dB
6 GHz to 7.5 GHz		92 dB	95 dB
7.5 GHz to 8.5 GHz		85 dB	88 dB
300 kHz to 3 MHz	IF bandwidth = 10 Hz		110 dB
3 MHz to 1.5 GHz		120 dB	123 dB
1.5 GHz to 4 GHz		122 dB	125 dB
4 GHz to 6 GHz		120 dB	122 dB
6 GHz to 7.5 GHz		117 dB	120 dB
7.5 GHz to 8.5 GHz		110 dB	113 dB

\*1. The test port dynamic range is calculated as the difference between the test port rms noise floor and the source maximum output power. The effective dynamic range must take measurement uncertainty and interfering signals into account.

\*2. May be limited to 90 dB at particular frequencies below 350MHz or above 4.2GHz due to spurious receiver residuals.

**Table 5-2 Corrected System Performance With Type-N Device Connectors, 85032F Calibration Kit**

Network analyzer: E5070A/E5071A, Calibration kit: 85032F (Type-N, 50 Ω), Calibration: full 2-port			
IF bandwidth = 10 Hz, No averaging applied to data, Environmental temperature = 23°C±5°C with <1°C deviation from calibration temperature, Isolation calibration not omitted			
Description	Specification (dB)		
	3 MHz to 3 GHz	3 GHz to 6 GHz	6 GHz to 8.5 GHz
Directivity	49	40	38
Source Match	41	36	35
Load Match	49	40	38
Reflection Tracking	±0.011	±0.032	±0.054
Transmission Tracking	±0.016	±0.062	±0.073

  

Transmission Uncertainty (Specification)	
<p><b>Magnitude</b></p>	<p><b>Phase</b></p>

Reflection Uncertainty (Specification)	
<p><b>Magnitude</b></p>	<p><b>Phase</b></p>

**Table 5-3 Corrected System Performance With Type-N Device Connectors, 85092C Electronic Calibration Module**

Network analyzer: E5070A/E5071A, Calibration module: 85092C (Type-N, 50 Ω) electronic calibration (ECal) module, Calibration: full 2-port			
IF bandwidth = 10 Hz, No averaging applied to data, Environmental temperature = 23°C±5°C with <1°C deviation from calibration temperature, Isolation calibration not omitted			
Description	Specification (dB)		
	3 MHz to 3 GHz	3 GHz to 6 GHz	6 GHz to 8.5 GHz
Directivity	52	52	47
Source Match	45	41	36
Load Match	47	44	39
Reflection Tracking	±0.040	±0.060	±0.070
Transmission Tracking	±0.039	±0.069	±0.136
<b>Transmission Uncertainty (Specification)</b>			
 <p>Magnitude Uncertainty [dB] Transmission Coefficient [dB] S11=S22=0 Source Power = -10 dBm</p>		 <p>Phase Uncertainty [degrees] Transmission Coefficient [dB] S11=S22=0 Source Power = -10 dBm</p>	
<b>Reflection Uncertainty (Specification)</b>			
 <p>Magnitude Uncertainty [linear] Reflection Coefficient [linear] S21=S12=0 Source Power = -10 dBm</p>		 <p>Phase Uncertainty [degrees] Reflection Coefficient [linear] S21=S12=0 Source Power = -10 dBm</p>	

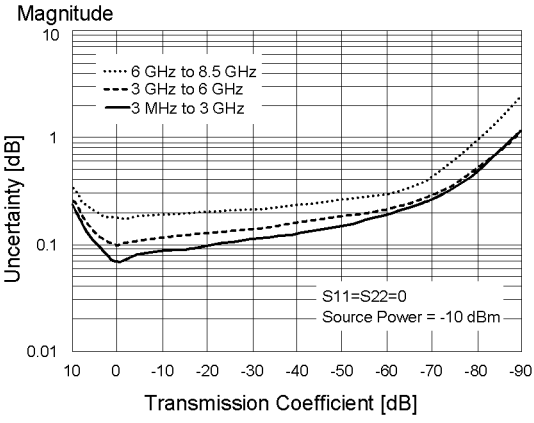
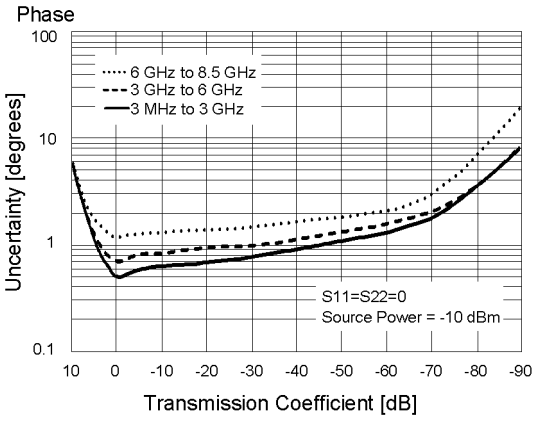
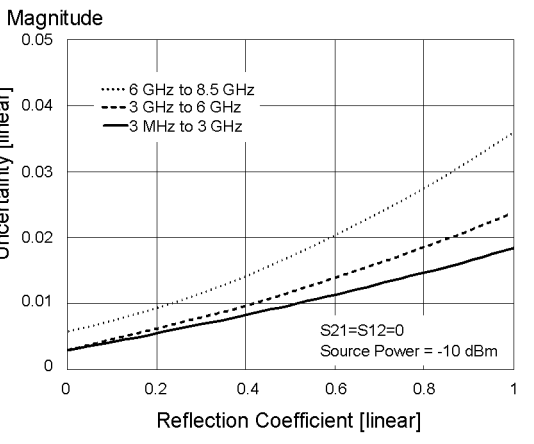
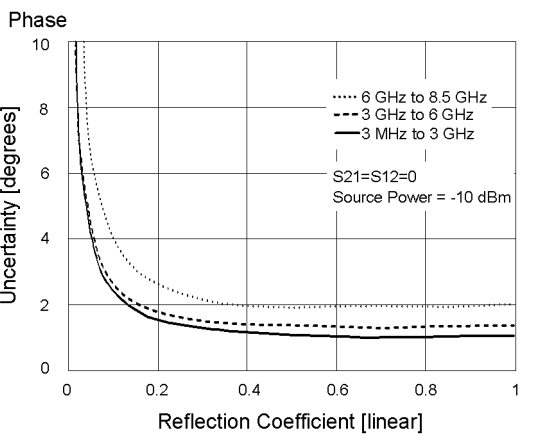
**Table 5-4** Corrected System Performance With 3.5 mm Device Connector Type, 85033E Calibration Kit

Network analyzer: E5070A/E5071A, Calibration kit: 85033E (3.5 mm, 50 Ω), Calibration: full 2-port			
IF bandwidth = 10 Hz, No averaging applied to data, Environmental temperature = 23°C±5°C with <1°C deviation from calibration temperature, Isolation calibration not omitted			
Description	Specification (dB)		
	3 MHz to 3 GHz	3 GHz to 6 GHz	6 GHz to 8.5 GHz
Directivity	46	38	38
Source Match	43	37	36
Load Match	46	38	38
Reflection Tracking	±0.006	±0.009	±0.010
Transmission Tracking	±0.016	±0.065	±0.069
Transmission Uncertainty (Specification)			
Reflection Uncertainty (Specification)			

**Table 5-5 Corrected System Performance With 3.5 mm Device Connector Type, 85093C Electronic Calibration Module**

Network analyzer: E5070A/E5071A, Calibration module: 85093C (3.5 mm, 50 Ω) electronic calibration (ECal) module, Calibration: full 2-port			
IF bandwidth = 10 Hz, No averaging applied to data, Environmental temperature = 23°C±5°C with <1°C deviation from calibration temperature, Isolation calibration not omitted			
Description	Specification (dB)		
	3 MHz to 3 GHz	3 GHz to 6 GHz	6 GHz to 8.5 GHz
Directivity	52	51	47
Source Match	44	39	34
Load Match	47	44	40
Reflection Tracking	±0.030	±0.050	±0.070
Transmission Tracking	±0.039	±0.069	±0.117
<b>Transmission Uncertainty (Specification)</b>			
<b>Reflection Uncertainty (Specification)</b>			

---

## Uncorrected System Performance

**Table 5-6**      **Uncorrected System Performance**

Description	Specification		
	3 MHz to 3 GHz	3 GHz to 6 GHz	6 GHz to 8.5 GHz
Directivity	10 dB	6 dB	4 dB
Source Match	15 dB	10 dB	10 dB
Load Match	17 dB	12 dB	12 dB
Transmission Tracking	$\pm 3.0$ dB, typical	$\pm 2.0$ dB, typical	$\pm 4.0$ dB, typical
Reflection Tracking	$\pm 3.0$ dB, typical	$\pm 2.0$ dB, typical	$\pm 4.0$ dB, typical

## Test Port Output (Source)

**Table 5-7 Test Port Output Frequency**

Description	Specification	Supplemental Information
Range E5070A E5071A	300 kHz to 3 GHz 300 kHz to 8.5 GHz	
Resolution	1 Hz	
Source Stability Standard Option 1E5		±5 ppm (5°C to 40°C, typical) ±0.05 ppm (23°C±5°C, typical) ±0.5 ppm/year (typical)
CW Accuracy Standard Option 1E5	±5 ppm, 23°C±5°C ±1 ppm, 23°C±5°C	

**Table 5-8 Test Port Output Power\*<sup>1</sup>**

Description	Specification	Supplemental Information
Level Accuracy (at 23°C±5°C) 300 kHz to 10 MHz  10 MHz to 8.5 GHz  Level Accuracy (high temperature mode: ON) 300 kHz to 8.5 GHz  Level Accuracy (swept mode: ON) 300 kHz to 4.2 GHz  4.2 GHz to 8.5 GHz	±0.650 dB (at 0 dBm, 50 MHz absolute) ±1.0 dB (at 0 dBm, relative to 50 MHz reference)	±1.0 dB (at 0 dBm, relative to 50 MHz reference)   ±0.8 dB (at 0 dBm, 50 MHz absolute) ±1.5 dB (at 0 dBm, relative to 50 MHz reference)  ±2.5 dB (at 0 dBm, relative to 50 MHz reference) ±3.5 dB (at 0 dBm, relative to 50 MHz reference)
Level Linearity (23°C±5°C) 10 MHz to 4.2 GHz 4.2 GHz to 8.5 GHz  Level Linearity (high temperature mode: ON) 300 kHz to 4.2 GHz 4.2 GHz to 8.5 GHz	±0.75 dB (at -15 dBm to 0 dBm) ±1.5 dB (at -10 dBm to 0 dBm) ±3 dB (at -15 dBm to 0 dBm)	±1.5 dB (at -15 dBm to 0 dBm)   ±1.5 dB (at -15 dBm to 0 dBm) ±2.0 dB (at -10 dBm to 0 dBm) ±3.5 dB (at -15 dBm to 0 dBm)

Specifications and Supplemental Information  
**Test Port Output (Source)**

**Table 5-8 Test Port Output Power<sup>\*1</sup>**

Description	Specification	Supplemental Information
Level Linearity (swept mode: ON) 300 kHz to 4.2 GHz 4.2 GHz to 8.5 GHz		±1.5 dB (at -15 dBm to 0 dBm) ±3 dB (at -5 dBm to 0 dBm) ±5 dB (at -10 dBm to 0 dBm) ±8 dB (at -15 dBm to 0 dBm)
Range Standard Extended Power Range (with option 214, 314, 414)	-15 dBm to 0 dBm	-50 dBm to 0 dBm (non-harmonics spurious may limit power range)
Level Resolution	0.05 dB	

\*1. Source output performance on port 1 only. Other port output performance is typical.

**Table 5-9 Test Port Output Signal Purity**

Description	Specification	Supplemental Information
Harmonics (2nd or 3rd) 10 MHz to 2 GHz 2 GHz to 3 GHz 3 GHz to 8.5 GHz		< -25 dBc (at -5 dBm, typical) < -15 dBc (at -5 dBm, typical) < -10 dBc (at -5 dBm, typical)
Non-Harmonic Spurious 10 MHz to 3 GHz 3 GHz to 8.5 GHz		< -25 dBc (at -5 dBm, typical) < -10 dBc (at -5 dBm, typical)



## Test Port Input

**Table 5-10 Test Port Input Levels**

Description	Specification	Supplemental Information
<b>Maximum Test Port Input Level</b>		
300 kHz to 8.5 GHz	+0 dBm max.	
<b>Damage Level</b>		
300 kHz to 8.5 GHz		+20 dBm, ±25 VDC, typical
<b>Crosstalk<sup>*1</sup></b>		
3 MHz to 3 GHz	-120 dB	
3 GHz to 6 GHz	-110 dB	
6 GHz to 7.5 GHz	-100 dB	
7.5 GHz to 8.5 GHz	-90 dB	

\*1. Response calibration not omitted.

**Table 5-11 Test Port Input (Trace Noise)**

Description	Specification	Supplemental Information
<b>Trace Noise<sup>*1</sup> Magnitude</b>		
300 kHz to 3 MHz		5 mdB rms (at IFBW = 3 kHz, typical) 8 mdB rms (at IFBW = 3 kHz, high temperature mode: ON, typical)
3 MHz to 4.2 GHz	1 mdB rms (at IFBW = 3 kHz)	4 mdB rms (at IFBW = 3 kHz, high temperature mode: ON, typical)
4.2 GHz to 7.5 GHz	3 mdB rms (at IFBW = 3 kHz)	6 mdB rms (at IFBW = 3 kHz, high temperature mode: ON, typical)
7.5 GHz to 8.5 GHz	5 mdB rms (at IFBW = 3 kHz)	8 mdB rms (at IFBW = 3 kHz, high temperature mode: ON, typical)

**Table 5-11 Test Port Input (Trace Noise)**

Description	Specification	Supplemental Information
<b>Trace Noise <sup>*1</sup> Phase</b>		
300 kHz to 3 MHz		0.035 ° rms (at IFBW = 3 kHz, typical) 0.05 ° rms (at IFBW = 3 kHz, high temperature mode: ON, typical)
3 MHz to 4.2 GHz		0.007 ° rms (at IFBW = 3 kHz, typical) 0.02 ° rms (at IFBW = 3 kHz, high temperature mode: ON, typical)
4.2 GHz to 7.5 GHz		0.021 ° rms (at IFBW = 3 kHz, typical) 0.035 ° rms (at IFBW = 3 kHz, high temperature mode: ON, typical)
7.5 GHz to 8.5 GHz		0.035 ° rms (at IFBW = 3 kHz, typical) 0.05 ° rms (at IFBW = 3 kHz, high temperature mode: ON, typical)

\*1. Trace noise is defined as a ratio measurement of a through, with the source set to 0 dBm.

**Table 5-12 Test Port Input (Stability)**

Description	Specification	Supplemental Information
<b>Stability Magnitude<sup>*1</sup></b>		
3 MHz to 3 GHz		0.005 dB/°C (at 23 °C±5°C, typical)
3 GHz to 6 GHz		0.01 dB/°C (at 23 °C±5°C, typical)
6 GHz to 8.5 GHz		0.04 dB/°C (at 23 °C±5°C, typical)
<b>Stability Phase<sup>*1</sup></b>		
3 MHz to 3 GHz		0.1 °/°C (at 23 °C±5°C, typical)
3 GHz to 6 GHz		0.2 °/°C (at 23 °C±5°C, typical)
6 GHz to 8.5 GHz		0.8 °/°C (at 23 °C±5°C, typical)

\*1. Stability is defined as a ratio measurement at the test port.

**Table 5-13 Test Port Input (Dynamic Accuracy)**

Accuracy of the test port input power reading is relative to -20 dBm reference input power level.	
Specification	Supplemental Information
<p><b>Magnitude</b></p> <p>Mag [dB]</p> <p>Test Port Power [dBm]</p>	<p><b>Phase</b></p> <p>Phase [deg]</p> <p>Test Port Power [dBm]</p>

**Table 5-14 Test Port Input (Group Delay)<sup>\*1</sup>**

Description	Specification	Supplemental Information
Aperture (selectable)	(frequency span)/(number of points – 1)	
Maximum Aperture	25% of frequency span	
Minimum Delay		Limited to measuring no more than 180° of phase change within the minimum aperture.
Accuracy		See graph below, typical

The following graph shows group delay accuracy with type-N full 2-port calibration and a 10 Hz IF bandwidth. Insertion loss is assumed to be < 2 dB.

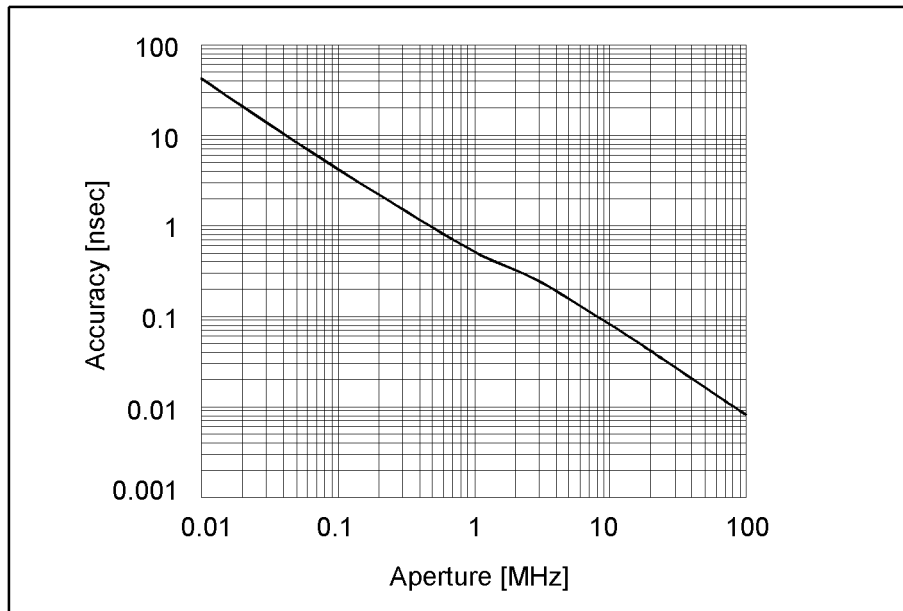

In general, the following formula can be used to determine the accuracy, in seconds, of specific group delay measurement:

$$\pm \text{Phase Accuracy (deg)} / [360 \times \text{Aperture (Hz)}]$$

\*1. Group delay is computed by measuring the phase change within a specified step (determined by the frequency span and the number of points per sweep).

## General Information

**Table 5-15 System Bandwidths**

Description	Supplemental Information
<b>IF Bandwidth Settings</b>	
Range	10 Hz to 100 kHz Nominal settings are: 10, 15, 20, 30, 40, 50, 70, 100, 150, 200, 300, 400, 500, 700, 1k, 1.5k, 2k, 3k, 4k, 5k, 7k, 10k, 15k, 20k, 30k, 40k, 50k, 70k, 100kHz

**Table 5-16 Front Panel Information**

Description	Supplemental Information
<b>RF Connectors</b>	
Type	Type-N, female, 50 $\Omega$ (nominal)
<b>Display</b>	
Size	10.4 in TFT color LCD
Resolution	VGA (640 $\times$ 480)

**Table 5-17 Rear Panel Information**





Description	Supplemental Information
<b>External Trigger Connector</b>	
Type	BNC, female
Input level	LOW threshold voltage: 0.5 V HIGH threshold voltage: 2.1 V Input level range: 0 to + 5 V
Pulse width	≥ 2 μsec, typical
Polarity	Negative (downward) only
<b>External Reference Signal Input Connector</b>	
Type	BNC, female
Input Frequency	10 MHz ± 10 ppm, typical
Input Level	0 dBm ± 3 dB, typical
<b>Internal Reference Signal Output Connector</b>	
Type	BNC, female
Output Frequency	10 MHz ± 10 ppm, typical
Signal Type	Sine Wave, typical
Output Level	0 dBm ± 3 dB into 50 Ω, typical
Output Impedance	50 Ω, nominal
<b>VGA Video Output</b>	15-pin mini D-Sub; female; drives VGA compatible monitors
<b>GPIO</b>	24-pin D-Sub (Type D-24), female; compatible with IEEE-488
<b>Parallel Port</b>	36-pin D-Sub (Type 1284-C), female; provides connection to printers
<b>USB Port</b>	
Contact 1	Universal Serial Bus jack, Type A configuration (4 contacts inline, contact 1 on left); female; provides connection to printer, ECal module or multiport test set  Vcc: 4.75 to 5.25 VDC, 500 mA, maximum  -Data  +Data  Ground
Contact 2	
Contact 3	
Contact 4	
<b>LAN</b>	10/100BaseT Ethernet, 8-pin configuration; auto selects between the two data rates
<b>Handler I/O Port</b>	36-pin D-sub, female; provides connection to handler system

**Table 5-17 Rear Panel Information**

Description	Supplemental Information
<b>Line Power</b> *1	
Frequency	47 Hz to 63 Hz
Voltage	90 to 132 VAC, or 198 to 264 VAC (automatically switched)
VA Max	350 VA max.

\*1. A third-wire ground is required.

**Table 5-18 EMC and Safety**

Description	Supplemental Information
<b>EMC</b>	
	<p>European Council Directive 89/336/EEC            EN / IEC 61326-1:1997+A1:1998            CISPR 11:1997+A1:1999 / EN 55011:1998+A1:1999 Group 1,            Class A            IEC 61000-4-2:1995 / EN 61000-4-2:1995 +A1:1998            4 kV CD / 4 kV AD            IEC 61000-4-3:1995 / EN 61000-4-3:1996 +A1:1998            3 V/m, 80-1000 MHz, 80% AM            IEC 61000-4-4:1995 / EN 61000-4-4:1995            1 kV power / 0.5 kV Signal            IEC 61000-4-5:1995 / EN 61000-4-5:1995            0.5 kV Normal / 1 kV Common            IEC 61000-4-6:1996 / EN 61000-4-6:1996            3 V, 0.15-80 MHz, 80% AM            IEC 61000-4-11:1994 / EN 61000-4-11:1994            100% 1cycle            Canada ICES001:1998            Note: The performance of EUT will be within the specification over the RF immunity tests according to EN 61000-4-3 or EN 61000-4-6 except under the coincidence of measurement frequency and interference frequency.</p>
<b>ICES/NMB-001</b>	This ISM device complies with Canadian ICES-001. Cet appareil ISM est conforme à la norme NMB-001 du Canada.
	AS/NZS 2064.1/2 Group 1, Class A
<b>Safety</b>	
	<p>European Council Directive 73/23/EEC            IEC 61010-1:1990+A1+A2 / EN 61010-1:1993+A2            INSTALLATION CATEGORY II, POLLUTION            DEGREE 2            INDOOR USE            IEC60825-1:1994 CLASS 1 LED PRODUCT</p>
	CAN/CSA C22.2 No. 1010.1-92

**Table 5-19 Analyzer Environment and Dimensions**

Description	Supplemental Information
<b>Operating Environment</b>	
Temperature	+5 °C to +40 °C
Error-Corrected Temperature Range	23 °C ± 5 °C with < 1°C deviation from calibration temperature
Humidity	< 90% at +40 °C (non-condensing)
Altitude	0 to 2,000 m (0 to 6,561 feet)
Vibration	0.5 G maximum, 5 Hz to 500 Hz
<b>Non-Operating Storage Environment</b>	
Temperature	-25 °C to +65 °C
Humidity	< 95% at +65 °C (non-condensing)
Altitude	0 to 4,572 m (0 to 15,000 feet)
Vibration	0.5 G maximum, 5 Hz to 500 Hz
<b>Dimensions</b>	See Figure 5-1 through Figure 5-3.
<b>Weight</b>	
Net	16 kg (Option 213/214, nominal) 18 kg (Option 413/414, nominal)

**Figure 5-1 Dimensions (front view, with Option 413, in millimeters, nominal)**

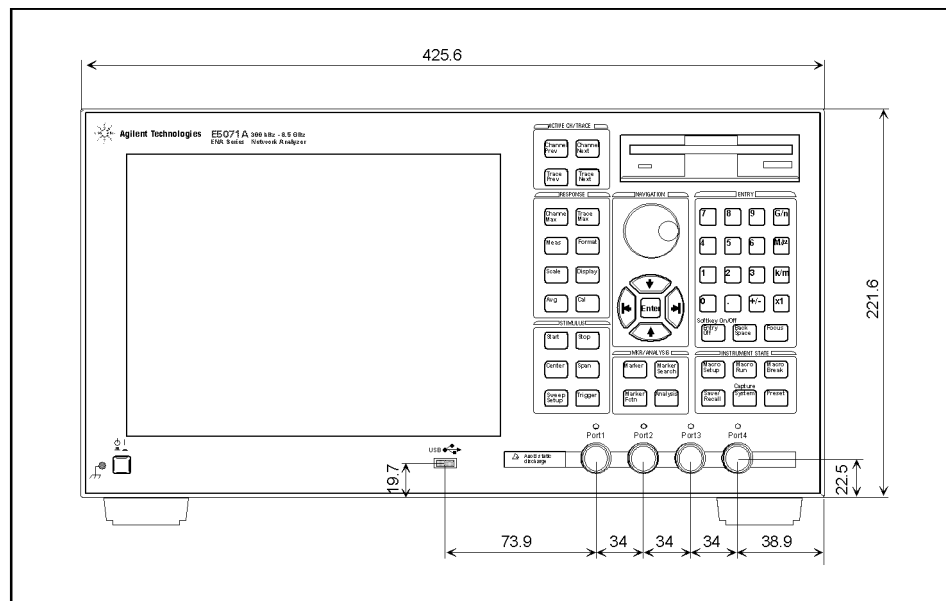

e5070aue001



**Figure 5-2**

**Dimensions (rear view, with Option 1E5, in millimeters, nominal)**

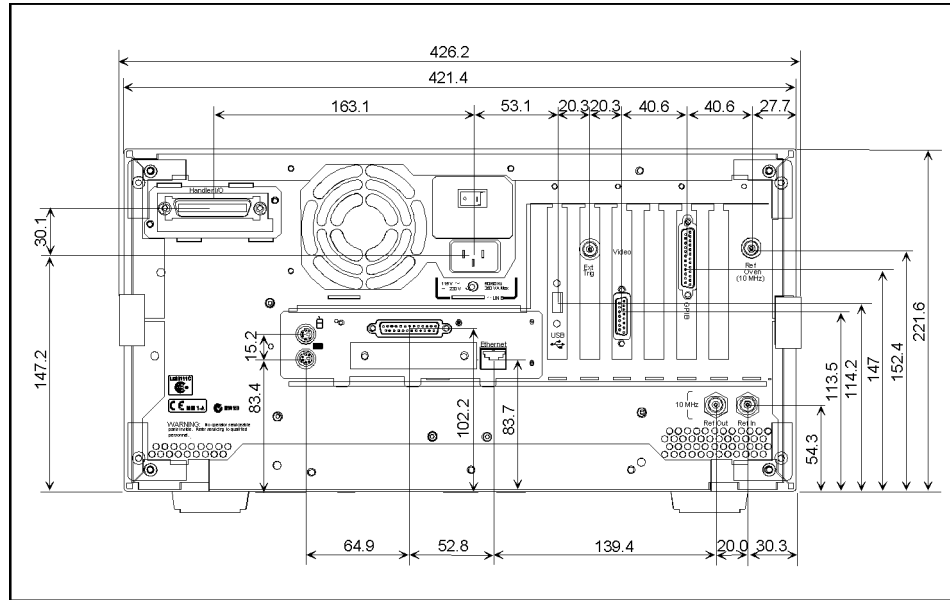

e5070aue002

**Figure 5-3**

**Dimensions (side view, in millimeters, nominal)**

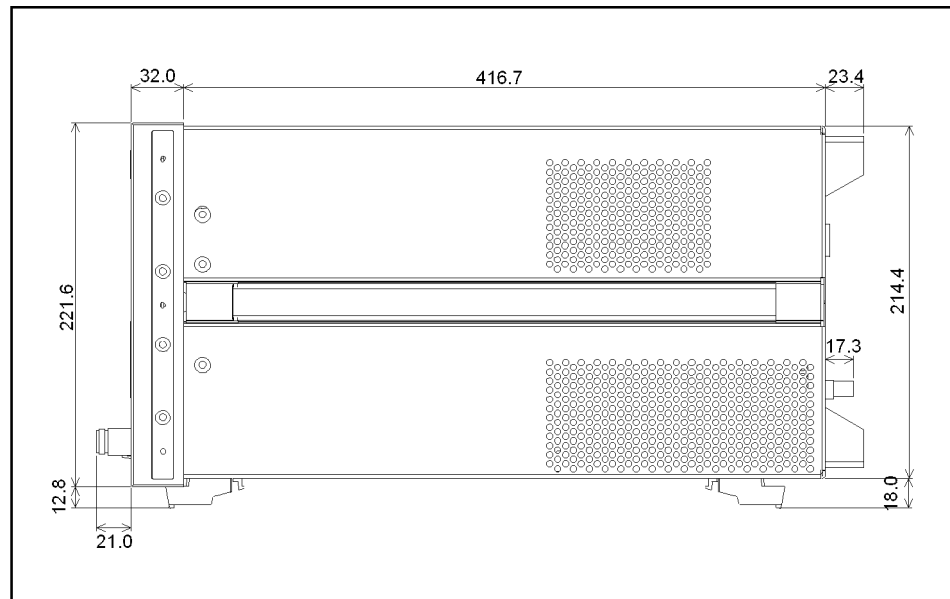

e5070aue003

## Measurement Throughput Summary

**Table 5-20** Typical Cycle Time for Measurement Completion <sup>\*1\*2</sup> (ms)

	Number of Points			
	51	201	401	1601
<b>Start 1 GHz, Stop 1.2 GHz, 100 kHz IF bandwidth</b>				
Uncorrected	4	5	7	18
2-port cal	5	8	13	42
<b>Start 300 kHz, Stop 3 GHz, 100 kHz IF bandwidth</b>				
Uncorrected	11	12	13	22
2-port cal	19	22	24	46
<b>Start 300 kHz, Stop 8.5 GHz, 100 kHz IF bandwidth</b>				
Uncorrected	19	23	24	24
2-port cal	37	45	46	49

\*1. Typical performance.

\*2. Sweep mode: Fast swept. Analyzer display turned off with :DISP:ENAB OFF. Number of traces = 1. System error correction: OFF.

**Table 5-21** Typical Cycle Time for Measurement Completion <sup>\*1\*2</sup> (ms)

	Number of Points			
	51	201	401	1601
<b>Start 1 GHz, Stop 1.2 GHz, 100 kHz IF bandwidth</b>				
Uncorrected	4	6	7	21
2-port cal	5	9	15	54
<b>Start 300 kHz, Stop 3 GHz, 100 kHz IF bandwidth</b>				
Uncorrected	11	12	13	23
2-port cal	19	22	24	54
<b>Start 300 kHz, Stop 8.5 GHz, 100 kHz IF bandwidth</b>				
Uncorrected	19	24	24	25
2-port cal	37	45	46	56

\*1. Typical performance.

\*2. Sweep mode: Fast swept. Analyzer display turned off with :DISP:ENAB OFF. Number of traces = 1. System error correction: ON.

**Table 5-22 Typical Cycle Time for Measurement Completion<sup>\*1\*2</sup> (ms)**

	Number of Points			
	51	201	401	1601
<b>Start 1 GHz, Stop 1.2 GHz, 100 kHz IF bandwidth</b>				
Uncorrected	7	17	29	90
2-port cal	12	32	55	178
<b>Start 300 kHz, Stop 3 GHz, 100 kHz IF bandwidth</b>				
Uncorrected	13	26	42	129
2-port cal	25	49	82	257
<b>Start 300 kHz, Stop 8.5 GHz, 100 kHz IF bandwidth</b>				
Uncorrected	15	29	49	146
2-port cal	28	56	95	289

\*1. Typical performance.

\*2. Sweep mode: Std Stepped. Analyzer display turned off with :DISP:ENAB OFF. Number of traces = 1. System error correction: ON

**Table 5-23 Cycle Time (ms)<sup>\*1\*2</sup> vs. Number of Points**

Number of Points	Sweep mode: Fast Swept System error correction: OFF	Sweep mode: Fast Swept System error correction: ON	Sweep mode: Std Stepped System error correction: ON
3	4	4	4
11	4	4	4
51	4	4	7
101	4	5	11
201	5	6	17
401	8	7	29
801	11	12	52
1601	18	21	90

\*1. Typical performance.

\*2. Start 1 GHz, Stop 1.2 GHz, 100 kHz IF bandwidth, Error correction: OFF, Display update: OFF, Number of traces = 1.

**Table 5-24      Data Transfer Time<sup>\*1</sup> (ms)**

	Number of Points			
	51	201	401	1601
<b>SCPI over GPIB (program executed on external PC)<sup>*2</sup></b>				
64-bit floating point	7	20	40	150
ASCII	20	75	149	587
<b>SCPI over 100 Mbps LAN (program executed on external PC)<sup>*2</sup></b>				
REAL 64	2	2	3	5
ASCII	37	140	274	1066
<b>COM (program executed in the analyzer)<sup>*3</sup></b>				
Variant type	1	1	1	1

\*1. Typical performance.

\*2. Measured using a VEE 5.0 program running on a 733 MHz Pentium III HP Kayak, Transferred complex S<sub>11</sub> data, using :CALC:DATA?SDATA.

\*3. Measured using an E5070A/E5071A VBA macro running inside the analyzer. Transferred complex S<sub>11</sub> data.

## Measurement capabilities

<b>Number of measurement channels</b>	Up to 9 independent measurement channels. A measurement channel is coupled to stimulus response settings including frequency, IF bandwidth, power level, and number of points.
<b>Number of display windows</b>	Each measurement channel has a display window. Up to 9 display windows (channels) can be displayed.
<b>Number of traces</b>	Up to 9 data traces and 9 memory traces per channel. 81 total traces and 81 memory traces can be displayed.
<b>Measurement choices</b>	Opt. 213/214: $S_{11}$ , $S_{21}$ , $S_{12}$ , $S_{22}$ Opt. 313/314: $S_{11}$ , $S_{21}$ , $S_{31}$ , $S_{12}$ , $S_{22}$ , $S_{32}$ , $S_{13}$ , $S_{23}$ , $S_{33}$ , Mixed-mode S-parameters, Balance parameters, CMRR Opt. 413/414: $S_{11}$ , $S_{21}$ , $S_{31}$ , $S_{41}$ , $S_{12}$ , $S_{22}$ , $S_{32}$ , $S_{42}$ , $S_{13}$ , $S_{23}$ , $S_{33}$ , $S_{43}$ , $S_{14}$ , $S_{24}$ , $S_{34}$ , $S_{44}$ , Mixed mode S-parameters, Balance parameters, CMRR
<b>Measurement parameter conversion</b>	Available to convert S-parameters into reflection impedance, transmission impedance, reflection admittance, transmission admittance, and 1/S.
<b>Data formats</b>	Log magnitude, linear magnitude, phase, extended phase, positive phase, group delay, SWR, real, imaginary, Smith chart, polar.
<b>Data markers</b>	10 independent markers per trace. Reference marker available for delta marker operation. Smith chart format includes 5 marker formats: linear magnitude/phase, log magnitude/phase, real/imaginary, $R + jX$ , and $G + jB$ . Polar chart format includes 3 marker formats: linear magnitude/phase, log magnitude/phase, and real/imaginary.
<b>Marker functions</b>	
<b>Marker search</b>	Max value, Min value, peak, peak left, peak right, target, target left, target right, bandwidth parameters with user-defined bandwidth values.
<b>Marker-to functions</b>	Set start, stop, center to active marker stimulus value; set reference to active marker response value.
<b>Tracking</b>	Performs marker search continuously or on demand.
<b>Time domain functions</b>	
<b>Transformation</b>	Selectable transformation type from bandpass, lowpass impulse, lowpass step. Selectable window from maximum, normal and minimum.
<b>Gated functions</b>	Selectable gated filter type from bandpass, notch. Selectable gate shape from maximum, normal and wide.

---

## Source control

<b>Measured number of points per sweep</b>	User definable from 2 to 1601.
<b>Sweep mode</b>	Normal stepped, normal swept, fast stepped and fast swept.
<b>Sweep type</b>	Linear sweep, segment sweep and log sweep.
<b>Segment sweep</b>	Define independent sweep segments. Set number of points, test port power levels, IF bandwidth, delay time, sweep time and sweep mode independently for each segment.
<b>Sweep trigger</b>	Set to continuous, hold, or single, sweep with internal, external, manual, or bus trigger.
<b>Power</b>	Set source power from -15 dBm (-50 dBm for option 214/314/414) to 0 dBm.

---

## Trace functions

<b>Display data</b>	Display current measurement data, memory data, or current measurement and memory data simultaneously.
<b>Trace math</b>	Vector addition, subtraction, multiplication or division of measured complex values and memory data.
<b>Title</b>	Add custom title to each channel window. Titles are printed on hardcopies of displayed measurements.
<b>Autoscale</b>	Automatically selects scale resolution and reference value to vertically center the trace.
<b>Electrical delay</b>	Offset measured phase or group delay by a defined amount of electrical delay, in seconds.
<b>Phase Offset</b>	Offset measured phase or group delay by a defined amount in degrees.
<b>Statistics</b>	Calculates and displays mean, standard deviation and peak-to-peak deviation of the data trace.

## Data accuracy enhancement

<b>Measurement calibration</b>	Measurement calibration significantly reduces measurement uncertainty due to errors caused by system directivity, source and load match, tracking and crosstalk. Full 2-port, 3-port, or 4-port calibration removes all the systematic errors for the related test ports to obtain the most accurate measurements.
<b>Calibration types available</b>	
<b>Response</b>	Simultaneous magnitude and phase correction of frequency response errors for either reflection or transmission measurements.
<b>Response and isolation</b>	Compensates for frequency response and crosstalk errors of transmission measurements.
<b>One-port calibration</b>	Available on test port 1, port 2, port 3, or port 4 to correct for directivity, frequency response and source match errors.
<b>Full 2-port/3-port/4-port calibration</b> <b>TRL calibration</b>	Compensates for directivity, source match, reflection tracking, load match, transmission tracking and crosstalk. Crosstalk calibration can be omitted.
<b>Interpolated error correction</b>	With any type of accuracy enhancement applied, interpolated mode recalculates the error coefficients when the test frequencies are changed. The number of points can be increased or decreased and the start/stop frequencies can be changed.
<b>Velocity factor</b>	Enter the velocity factor to calculate the equivalent physical length.
<b>Reference port extension</b>	Redefine the measurement plane from the plane where the calibration was done.

## Storage

<b>Internal hard disk drive</b>	Store and recall instrument states, calibration data, and trace data on 3 GB, minimum, internal hard drive. Trace data can be saved in CSV (comma separated value) format. All files are MS-DOS® -compatible. Instrument states include control settings, limit lines, segment sweep tables, and memory trace data.
<b>File sharing</b>	Internal hard disk drive (D:) can be accessed from an external Windows® PC through LAN.
<b>Disk drive</b>	Instrument states, calibration data, and trace data can be stored on an internal 3.5 inch 1.4MB floppy disk in MS-DOS® -compatible format.
<b>Screen hardcopy</b>	Printouts of instrument display are directly produced on a printer. The analyzer provides USB and parallel interfaces.

## System capabilities

<b>Familiar graphical user interface</b>	The ENA Series analyzer employs a graphical user interface based on the Windows® operating system. There are three ways to operate the instrument manually: you can use a hardkey interface, a touch screen interface (Opt. 016), or a mouse interface.
<b>Limit lines</b>	Define the test limit lines that appear on the display for pass/fail testing. Defined limits may be any combination of horizontal/sloping lines and discrete data points.
<b>Fixture Simulator</b>	
<b>Balanced-unbalanced conversion</b>	Convert data from single-ended measurement to balanced measurement parameters (mixed-mode S-parameters), balance parameter or CMRR by using internal software.
<b>Network De-embedding</b>	De-embed an arbitrary circuit defined by a two-port Touchstone data file for each test port. This function eliminates error factors between the calibration plane and DUT and expands the calibration plane for each test port. This function can be used with the port extension function.
<b>4-port Network Embedding/De-embedding</b>	Embed or de-embed an arbitrary circuit defined by a four-port Touchstone data file.
<b>Port reference impedance conversion</b>	Convert S-parameters measured in 50 Ω reference impedance to data in other reference impedance levels by using internal software. This conversion can be performed for both single-ended (unbalanced) measurement ports and converted balanced measurement ports.
<b>Matching circuit</b>	Add one of the predefined matching circuits or a circuit defined by a two-port Touchstone data file to each single-ended test port or converted balanced (differential) test port by using internal software.



## Automation

<b>Methods</b>	
<b>Internal analyzer execution</b>	Applications can be developed in a built-in VBA® (Visual Basic for Applications) language. Applications can be executed from within the analyzer via COM (component object model) or using SCPI.
<b>Controlling via GPIB</b>	The GPIB interface operates to IEEE 488.2 and SCPI protocols. The analyzer can either be the system controller, or talker/listener.
<b>LAN</b>	
<b>Standard conformity</b>	10 Base-T or 100 Base-TX (automatically switched), Ethertwist, RJ45 connector
<b>Protocol</b>	TCP/IP
<b>Function</b>	Telnet



## REGIONAL SALES AND SUPPORT OFFICES

*For more information about Agilent Technologies test and measurement products, applications, services, and for a current sales office listing, visit our web site: <http://www.agilent.com/find/tmdir>. You can also contact one of the following centers and ask for a test and measurement sales representative.* 11/29/99

### **United States:**

Agilent Technologies  
Test and Measurement Call Center  
P.O.Box 4026  
Englewood, CO 80155-4026  
(tel) 1 800 452 4844

(fax) (61 3) 9272 0749  
(tel) 0 800 738 378 (New Zealand)  
(fax) (64 4) 802 6881

### **Canada:**

Agilent Technologies Canada Inc.  
5150 Spectrum Way  
Mississauga, Ontario  
L4W 5G1  
(tel) 1 877 894 4414

### **Asia Pacific:**

Agilent Technologies  
24/F, Cityplaza One, 1111 King's Road,  
Taikoo Shing, Hong Kong  
(tel) (852)-3197-7777  
(fax) (852)-2506-9284

### **Europe:**

Agilent Technologies  
Test & Measurement  
European Marketing Organization  
P.O.Box 999  
1180 AZ Amstelveen  
The Netherlands  
(tel) (31 20) 547 9999

### **Japan:**

Agilent Technologies Japan Ltd.  
Call Center  
9-1, Takakura-Cho, Hachioji-Shi,  
Tokyo 192-8510, Japan  
(tel) (81) 426 56 7832  
(fax) (81) 426 56 7840

### **Latin America:**

Agilent Technologies  
Latin American Region Headquarters  
5200 Blue Lagoon Drive, Suite #950  
Miami, Florida 33126  
U.S.A.  
(tel) (305) 267 4245  
(fax) (305) 267 4286

### **Australia/New Zealand:**

Agilent Technologies Australia Pty Ltd  
347 Burwood Highway  
Forest Hill, Victoria 3131  
(tel) 1-800 629 485 (Australia)